



32"/ 40" LCD TV

DX-32L221A12/ DX-40L260A12

USER GUIDE

Dynex DX-32L221A12/ DX-40L260A12

32"/ 40" LCD TV

Contents

CHILD SAFETY	1
Important safety instructions	2
Warnings	2
Cautions	2
Installing the stand or wall-mount bracket	4
Installing the stand	4
Installing a wall-mount bracket	4
TV components	5
Package contents	5
Front	5
Back and Side	5
Remote control	6
Making connections	7
What connection should I use?	7
Connecting power	8
Connecting a cable or satellite box	8
Connecting a DVD or Blu-ray player	11
Connecting a VCR	13
Connecting a camcorder or game console	14
Connecting a computer	14
Connecting headphones	15
Connecting a basic home theater system	15
Connecting a home theater system with multiple devices	16
Using the remote control	17
Installing remote control batteries	17
Aiming the remote control	17
Turning on your TV for the first time	17
Understanding the basics	18
Turning your TV on or off	18
Selecting the video input source	18
Using the on-screen menus	18
Navigating the menus	19
Selecting a channel	19
Adjusting the volume	19
Viewing channel information	20
Adjusting the picture	20
Adjusting the TV picture	20
Adjusting the computer image	21
Adjusting the sound	21
Adjusting sound settings	21
Playing TV audio only	22
Changing channel settings	22
Automatically scanning for channels	22
Hiding channels	23
Setting up a favorite channel list	23
Viewing a favorite channel	24
Adding or changing a channel label	24

Checking the digital signal strength	24
Setting parental controls	24
Setting or changing the password	24
Locking control buttons	25
Setting parental control levels	26
Downloading rating information	27
Using closed captioning	28
Turning closed captioning on or off	28
Selecting the analog closed captioning mode	28
Customizing digital closed captioning styles	29
Adjusting time settings	30
Setting the clock	30
Setting the sleep timer	30
Adjusting menu settings	31
Selecting the menu language	31
Labeling an input source	31
Restoring settings to the defaults	32
Maintaining	32
Cleaning the TV cabinet	32
Cleaning the TV screen	32
Upgrading the firmware	32
Troubleshooting	33
Video and audio	33
Remote control	34
General	34
Programming universal remote controls	36
Programming a different universal remote control	36
For additional help and information... ..	36
Common universal remote control codes	36
Legal notices	37
One-year limited warranty - Dynex Televisions	39
US and Canada Market	39

CHILD SAFETY

It makes a difference how and where you use your flat panel display

As you enjoy your new product, keep these safety tips in mind

The issue

The home theater entertainment experience is a growing trend, and larger TVs are popular purchases. However, TVs are not always supported on the proper stands or installed according to the manufacturer's recommendations. We and the consumer electronics industry are committed to making home entertainment enjoyable and safe.

TVs that are inappropriately placed on dressers, bookcases, shelves, desks, speakers, chests, or carts may fall over and cause injury.

Tune into safety

- One size of TV stand does **not** fit all. Use only a TV stand rated for the weight of your TV.
- Carefully read and understand all enclosed instructions for proper use of this product.
- Don't let children climb on or play with entertainment system furniture and TVs.
- Don't place TVs on furniture that can easily be used as steps, such as a crate or chest of drawers.
- Remember that children can become excited while watching a program, especially on a "larger-than-life" TV. Make sure that you place or install the TV where it cannot be pushed, pulled over, or knocked down.
- Make sure that you route all cords and cables so that they cannot be pulled or grabbed by curious children.



Wall mounting

If you decide to wall mount your TV, always remember:

- One size of wall mount does **not** fit all. Use only a wall mount rated for the weight of your TV and that has been recommended by this TV manufacturer, listed in this manual, or otherwise listed by an independent laboratory as suitable for your TV.
- Follow all instructions supplied by the TV and wall mount manufacturers.
- If you have any doubts about your ability to safely wall mount your TV, get help from a professional installer.
- Make sure that the wall where you are mounting the TV is appropriate. Some wall mounts are not designed to be mounted to walls backed with steel studs or cinder blocks. If you are unsure, ask a professional installer.
- TVs can be heavy. At least two people are required for safe wall mount installation.



Important safety instructions



This symbol indicates that dangerous voltage constituting a risk of electric shock is present within your TV. This label is located on the back of your TV.



This symbol indicates that there are important operating and maintenance instructions in the literature accompanying your TV.

- 1 Read these instructions.
- 2 Keep these instructions.
- 3 Heed all warnings.
- 4 Follow all instructions.
- 5 Do not use this apparatus near water.
- 6 Clean only with a dry cloth.
- 7 Do not block any ventilation openings. Install in accordance with the manufacturer's instructions.
- 8 Do not install near any heat sources such as radiators, heat registers, stoves, or other apparatus (including amplifiers) that produce heat.
- 9 Do not defeat the safety purpose of the polarized or grounding-type plug. A polarized plug has two blades with one wider than the other. A grounding type plug has two blades and a third grounding prong. The wide blade or the third prong are provided for your safety. If the provided plug does not fit into your outlet, consult an electrician for replacement of the obsolete outlet.
- 10 Protect the power cord from being walked on or pinched particularly at plugs, convenience receptacles, and the point where they exit from the apparatus.
- 11 Only use attachments/accessories specified by the manufacturer.
- 12 Use only with a cart, stand, tripod, bracket, or table specified by the manufacturer, or sold with the apparatus. When a cart is used, use caution when moving the cart/apparatus combination to avoid injury from tip-over.  S3125A
- 13 Unplug this apparatus during lightning storms or when unused for long periods of time.
- 14 Refer all servicing to qualified service personnel. Servicing is required when the apparatus has been damaged in any way, such as power-supply cord or plug is damaged, liquid has been spilled or objects have fallen into the apparatus, the apparatus has been exposed to rain or moisture, does not operate normally, or has been dropped.
- 15 The wall plug is the disconnecting device. The plug must remain readily operable.
- 16 An apparatus with three-prong, grounding-type plug is a Class I apparatus. Class I apparatus which needs to be grounded to prevent possible electric shock. Make sure that you connect the Class I apparatus to a grounding-type, three-prong outlet.
- 17 Remote control batteries should not be exposed to excessive heat such as sunshine, fire, or the like.

- 18 The apparatus should not be exposed to dripping or splashing, and no objects filled with liquids, such as vases, should be placed on the apparatus.

Warnings

Electric shock hazard

To reduce the risk of fire or electric shock, do not remove any cover or expose the device to rain or moisture. No user-serviceable parts are inside. Refer servicing to qualified service technicians.

Lightning

For added protection for your device receiver during a lightning storm, or when it is left unattended and unused for long periods of time, unplug it from the power outlet and disconnect any antenna or cable system. This helps prevent property damage and personal injury from lightning and power line surges.

Power lines

An outside antenna system should not be located in the vicinity of overhead power lines or other electric light or power circuits, or where it can fall into such power lines or circuits. When installing an outside antenna system, extreme care should be taken to keep from touching such power lines or circuits as contact with them might be fatal.

Handling the LCD panel

- Your TV's screen is made of glass. Do not drop your TV or hit, jolt, or press hard against the LCD panel. If the screen breaks, be careful of broken glass.
- If the LCD panel is broken, make absolutely sure that you do not touch the liquid in the panel. This may cause skin inflammation.
- If the liquid gets in your mouth, immediately gargle, rinse, and consult with your doctor. Also, if the liquid gets in your eyes or touches your skin, consult with your doctor after rinsing for at least 15 minutes or longer in clean water.

Replacement parts

When replacement parts are required, make sure that the service technician uses replacement parts specified by the manufacturer that have the same characteristics as the original part. Unauthorized substitutions may result in fire, electric shock, personal injury, or other hazards.

Safety check

After completing any service or repair to this device, ask the service technician to perform routine safety checks to determine that your TV is in correct operating condition.

Power source

Operate your TV only from the type of power source indicated on the marking label. If you are not sure of the type of power supplied to your home, consult an electrician or your local power company.

Cautions

Damage requiring service

Unplug this TV from the power outlet and refer servicing to qualified service personnel under the following conditions:

- When the power supply cord or plug is damaged or frayed.
- If liquid has been spilled or objects have fallen into your TV.
- If your TV has been exposed to rain or water.
- If your TV does not operate normally by following the operating instructions. Adjust only those controls that are covered by the operating instructions because incorrect adjustment of other

controls may result in damage and will often require extensive work by a qualified technician to restore your TV to its normal operation.

- If your TV has been dropped or damaged in any way.
- When your TV exhibits a distinct change in performance.

Outdoor antenna grounding

If an outside antenna or cable system is connected to your TV, make sure that the antenna or cable system is grounded to provide some protection against voltage surges and built-up static charges. Article 810 of the National Electrical Code, ANSI/NFPA No. 70, provides information with respect to correct grounding of the mast and supporting structure, grounding of the lead-in wire to an antenna discharge unit, size of grounding conductors, location of the antenna-discharge unit, connection to grounding electrodes, and requirements for the grounding electrode.

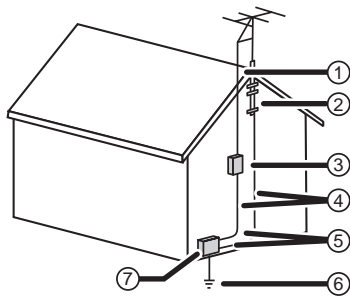

①	Antenna lead-in wire
②	Grounding clamp
③	Antenna discharge unit
④	Grounding conductors
⑤	Ground clamps
⑥	Power service grounding electrode system
⑦	Electric service equipment

Note to CATV system installer

Article 820 of the National Electrical Code, ANSI/NFPA No. 40 provides guidance for correct grounding. Specifically, it states that the cable ground must be connected to the grounding system of the building as close to the point of cable entry as practical.

Condensation

Moisture will form on the TV if the TV is brought from cool surroundings into a warm room or if the temperature of the room rises suddenly. When this happens, the TV's performance may be impaired. To prevent this, let the TV stand in its new surroundings for about an hour before switching it on, or make sure that the room temperature rises gradually. Condensation may also form during the summer if the TV is exposed to the breeze from an air conditioner. In such cases, change the location of the TV.

Mobile telephone warning

To avoid interference with your TV picture and sound, operating problems, or even damage, keep your cordless and cellular telephones away from the TV.

End of life directives

Your TV contains tin-lead solder and a fluorescent lamp containing a small amount of mercury. Disposal of these materials may be regulated for environmental reasons. Your TV also contains material that can be recycled and reused.

Non-active pixels

The LCD panel contains almost 3 million thin film transistors, which provide exceptionally sharp video quality. Occasionally, a few non-active pixels may appear on the screen as a fixed blue, green, or red point. These non-active pixels do not adversely affect the performance of your TV, and are not considered defects.

Installing the stand or wall-mount bracket

Notes

If you plan to wall-mount your TV, do not install the stand.
Store the stand and stand screws in case you want to decide to use the stand in the future.

Installing the stand

To install the stand:

- 1 Carefully place your TV screen face-down on a cushioned, clean surface to protect the screen from damages and scratches.

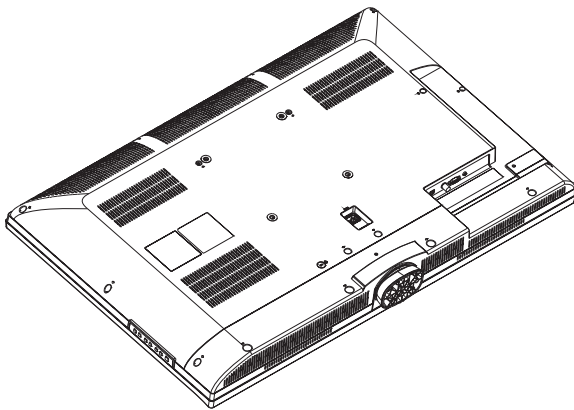

- 2 Secure the stand to the screen with the four provided screws.

Model	Screw type	Screw length
DX-32L221A12	Q4 type	25 mm
DX-40L260A12	Q4 type	25 mm

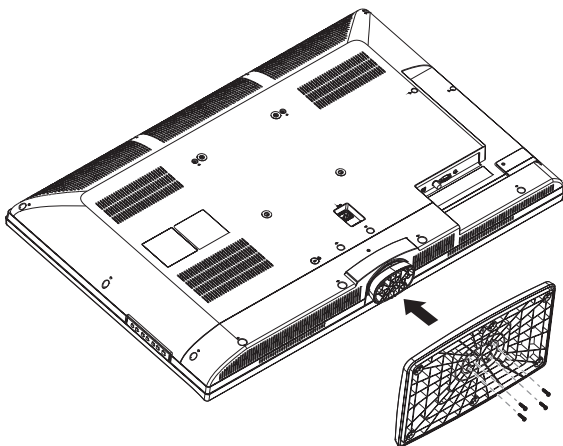

Installing a wall-mount bracket

Warning

This apparatus is intended to be supported by a UL Listed wall mount bracket.

To attach your TV to a wall-mount bracket:

- 1 Carefully place your TV screen face-down on a cushioned, clean surface to protect the screen from damages and scratches.

- 2 Remove the four screws that secure the base to the stand, then remove the base.

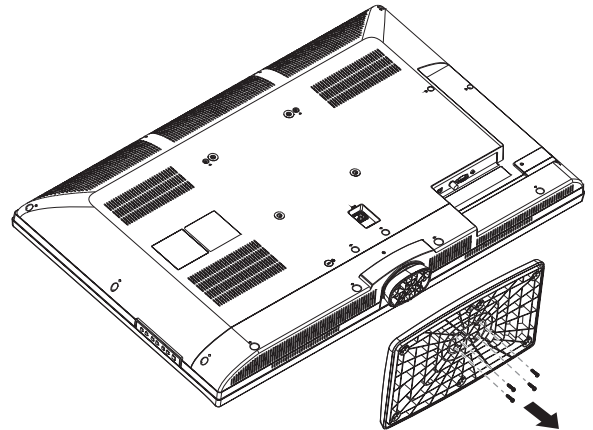

- 3 Remove the four screws that secure the stand column, then remove the column.

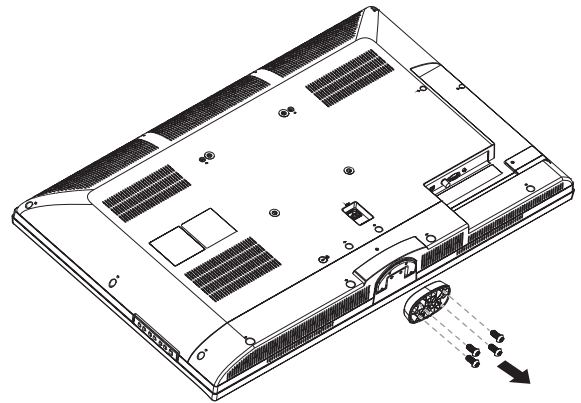

- 4 Attach the wall-mount bracket to your TV using the mounting holes on the back of your TV. See the instructions that came with the wall-mount bracket for information about how to correctly hang your TV.

Note

The length of the wall-mount screws vary depending on the wall-mount bracket you purchased. See the instructions that came with the wall-mount bracket for screw lengths.

DX-32L221A12 (32-inch)
DX-40L260A12 (40-inch)

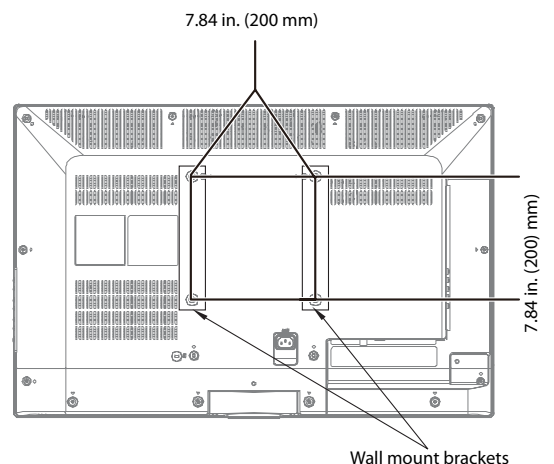

TV components

Package contents

- Remote control and batteries (2 AAA)
- Stand with screws
- Composite video cable
- Power cord
- *Quick Setup Guide*

Front

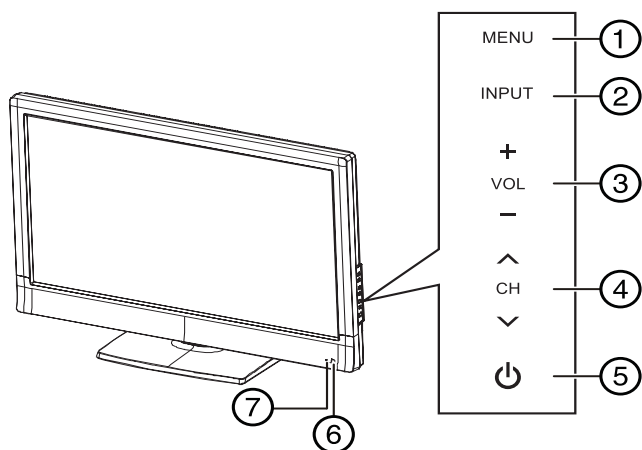

#	Item	Description
①	MENU	Press to open the on-screen menu. For more information, see "Navigating the menus" on page 19.
②	INPUT	Press to open the <i>Input Source</i> list, then press ▲ or ▼ to select a video input source. In menu mode, press to confirm selections.
③	VOL+/VOL-	Press to increase or decrease the volume.
④	CH ^/CH v	Press to go to the next or previous channel in the channel list. For more information, see "Selecting a channel" on page 19.
⑤	⏻ (power)	Press to turn your TV on or off (Standby mode). When your TV is off, power still flows into it. To disconnect power, unplug the power cord.
⑥	Remote control sensor	Receives the signals from the remote control. Do not block.
⑦	Power indicator	Lights red when your TV is in standby mode. Flashes red when your TV receives no signal from VGA and enters DPMS mode. Off when power cord is unplugged. For more information, see "Turning your TV on or off" on page 18.

Back and Side

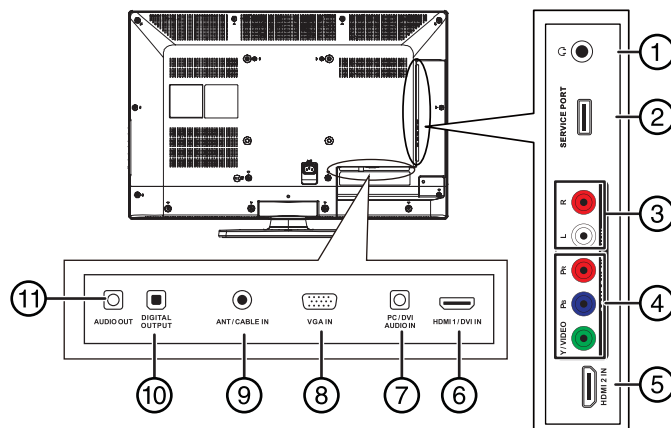

#	Item	Description
①	🎧 (headphone)	Connect headphones to this jack. For more information, see "Connecting headphones" on page 15.
②	Service port	For firmware update only. Do not use.
③	L/R audio	Connect the audio for a component video device to these jacks. For more information, see "Using component video (better)" on pages 9 or 12.
④	COMPONENT/Y-VIDEO/PB/PR	Connect the video for a component video device to these jacks, or connect the video cable from a composite video device to the "Y" jack. For more information, see "Using component video (better)" on pages 9 or 12, or "Using composite video (good)" on page 13. Note: The Y/VIDEO (composite) jack shares the audio jacks with the Y/PB/PR (component video) jacks.
⑤	HDMI 2	Connect HDMI devices to this jack. An HDMI cable carries both video and sound. You do not need to make an audio connection for an HDMI device. For more information, see "Using HDMI (best)" on pages 8, 11, or 15. When connecting a DVI device using an HDMI-DVI adapter, connect the device to the HDMI1 jack.
⑥	HDMI 1/DVI	Connect HDMI devices to this jack. An HDMI cable carries both video and sound. You do not need to make an audio connection for an HDMI device. For more information, see "Using HDMI (best)" on pages 8, 11, or 15. When connecting a DVI device using an HDMI-DVI adapter, connect the device to the HDMI1 jack.
⑦	PC/DVI AUDIO IN	Connect the audio for a computer or a DVI device to this jack. For more information, see "Using VGA" on page 14 or "Using DVI (same as HDMI but requires an audio connection)" on pages 9 or 12.
⑧	VGA IN	Connect the video (VGA) for a computer to this jack. For more information, see "Using VGA" on page 14.

#	Item	Description
⑨	ANT/CABLE	Connect an antenna or cable TV to this jack. For more information, see "Connecting an antenna or cable TV (no box)" on page 11.
⑩	DIGITAL OUTPUT	Connect an audio amplifier to this jack. For more information, see "Using digital audio" on page 15.
⑪	AUDIO OUT	Connect an external sound system to this jack. For more information, see "Using analog audio" on page 16.

Remote control

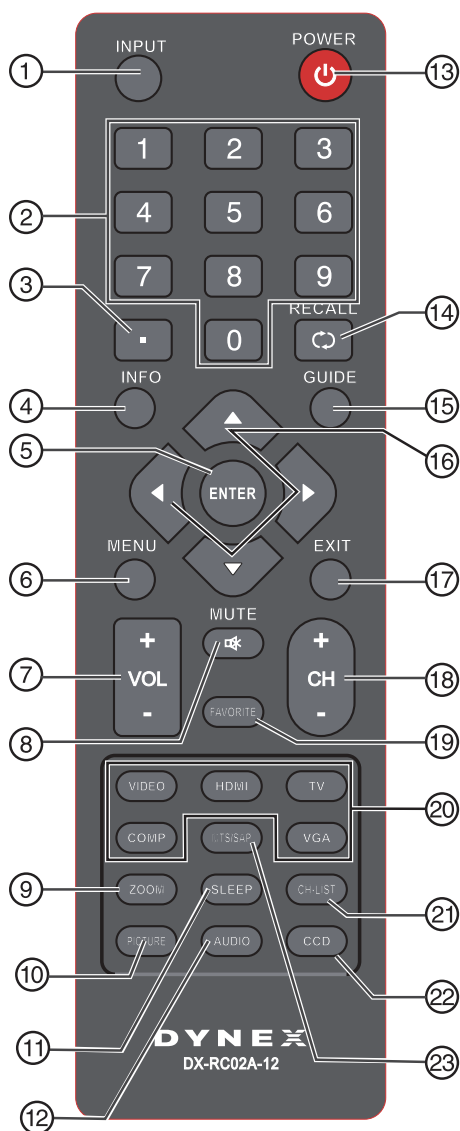

#	Button	Description
①	INPUT	Press to open the <i>Input Source</i> list, then press ▲ or ▼ to cycle through the available input sources. For more information, see "Selecting the video input source" on page 18.
②	Numbers	Press to enter channel numbers and the parental control password.
③	●	Press to enter a digital sub-channel number. For more information, see "Selecting a channel" on page 19.







#	Button	Description
④	INFO	Press to display TV status information, such as the channel number, channel name (if available), or signal source. For more information, see "Viewing channel information" on page 20.
⑤	ENTER	Press to confirm selections or changes.
⑥	MENU	Press to open the on-screen menu.
⑦	VOL +/VOL -	Press to increase or decrease the volume.
⑧	MUTE	Press to mute the sound. Press again to restore the sound.
⑨	ZOOM	Press to select the aspect ratio. For more information, see "Adjusting the TV picture" on page 20.
⑩	PICTURE	Press to select the video modes. You can select Vivid , Standard , Energy Savings , or Custom . For more information, see "Adjusting the TV picture" on page 20.
⑪	SLEEP	Press to set the sleep timer. You can select Off , 5 , 10 , 15 , 30 , 60 , 90 , 120 , 180 , or 240 minutes. For more information, see "Setting the sleep timer" on page 30.
⑫	AUDIO	Press to select the sound settings. For more information, see "Adjusting sound settings" on page 21.
⑬	⏻ (power)	Press to turn your TV on or off (Standby mode). When your TV is off, power still flows into it. To disconnect power, unplug the power cord.
⑭	RECALL	In TV mode, press to return to the previous channel.
⑮	GUIDE	Press to display the program guide. For more information, see "Viewing channel information" on page 20.
⑯	▲ ▼ ◀ ▶	Press to move up, down, left, or right in on-screen menus.
⑰	EXIT	Press to close the on-screen menu.
⑱	CH +/CH-	Press to change TV channels to the next higher or next lower channel. For more information, see "Selecting a channel" on page 19.
⑲	FAVORITE	Press to open the Favorite Channel list. For more information, see "Setting up a favorite channel list" on page 23 and "Viewing a favorite channel" on page 24.
⑳	Video input	VIDEO —Press to select the device connected to the AV IN jacks. HDMI —Press one or more times to select the device connected to the HDMI 1 or HDMI 2 jack. TV —Press to select the TV input source. COMP —Press to select the device connected to the COMPONENT video jacks. VGA —Press to select the device connected to the PC IN VGA jack.
㉑	CH-LIST	Press to open the channel list.
㉒	CCD	Press to turn closed captioning on or off. You can select CC Off , CC On , or CC On When Mute . For more information, see "Turning closed captioning on or off" on page 28.
㉓	MTS/SAP	Press to select the audio mode for an analog program. You can select: • Mono —Select this option if there is noise or static on weak stereo broadcasts. • Stereo —Select this option for programs broadcast in stereo. • SAP —Select this option to listen to a secondary audio program, if available.





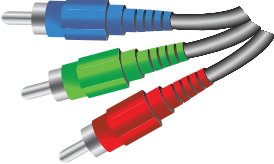

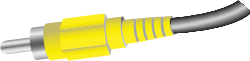
Making connections

What connection should I use?

Your TV has several connection types for connecting devices to your TV. For the best video quality, you should connect a device to the best available connection.

Use the following tables to identify cables:

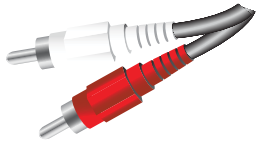
Connection type and jack	Video quality	Cable connector
HDMI video/audio 	Best (use this if your devices have HDMI)	
Component video (requires an audio connection) 	Better than composite, or coaxial	
Composite video (requires an audio connection) 	Better than coaxial	
Coaxial video/audio 	Good	

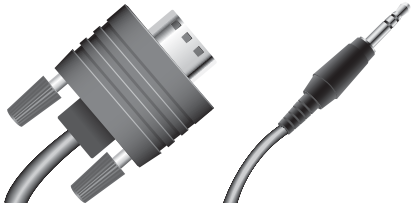
Connection type and jack	Cable connectors
Digital optical audio (SPDIF) output 	
Audio out 	
Analog audio 	
VGA (computer) video and audio 	

You can use an HDMI jack to connect a DVI device to your TV. You need to attach an HDMI-to-DVI adapter to the end of the HDMI cable that connects to the DVI device.

- Cautions**
- Check the jacks for position and type before making any connections.
 - Loose connections can result in image or color problems. Make sure that all connections are tight and secure.
 - The external audio/video equipment shown may be different from your equipment. If you have questions, refer to the documentation that came with your equipment.
 - Always unplug the power cord when connecting external equipment.

Connecting power

To connect the power:

- Connect the AC power cord to the AC connector on the back of your TV, then plug the other end into a power outlet.

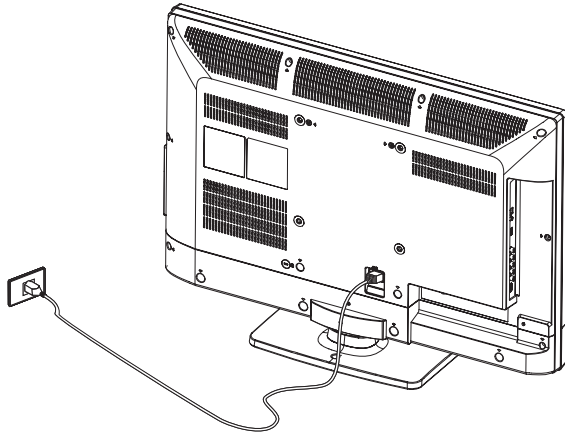

Notes

- Your TV should only be operated from the power source indicated on the label.
- Always unplug the AC power cord from the power outlet when you will not be using your TV for an extended period of time.

Connecting a cable or satellite box

Many cable or satellite TV boxes have more than one connection type. To get the best video, you should use the best connection type available. For more information, see "What connection should I use?" on page 7.

Using HDMI (best)

To connect a cable or satellite box using HDMI:

- 1 Turn off your TV and all connected equipment.
- 2 Connect the incoming cable from the cable wall jack to the cable-in jack on the cable box.
- 3 Connect an HDMI cable (not included) to one of the HDMI jacks on the back of your TV and to the HDMI Out jack on your cable or satellite box.

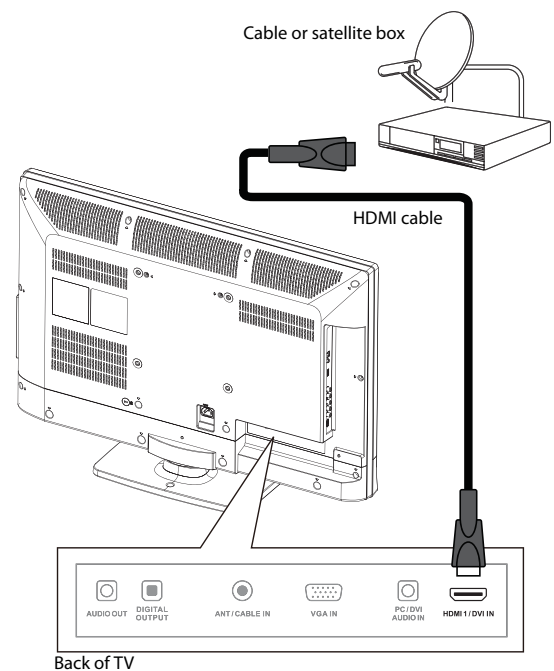

- 4 Turn on your TV, then turn on the cable or satellite box.
- 5 Go through the setup wizard on page 18.

Notes

An HDMI cable carries both audio and video. You do not need to use any audio cables.

Using DVI (same as HDMI but requires an audio connection)

Note
A DVI device must be connected to the **HDMI 1** jack. If you connect a DVI device to the **HDMI 2** jack, you will not hear audio.

To connect a cable or satellite box using DVI:

- 1 Turn off your TV and all connected equipment.
- 2 Connect the incoming cable from the cable wall jack to the cable-in jack on the cable box.
- 3 Connect an HDMI-DVI adapter (not included) to one end of an HDMI cable (not included).
- 4 Connect the HDMI-DVI adapter to the **HDMI 1** jack on the back of your TV and to the **DVI OUT** jack on the cable or satellite box.

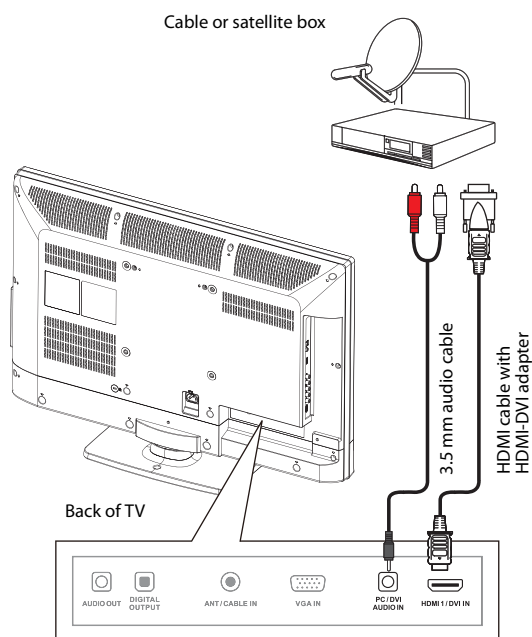

- 5 Connect a 3.5 mm audio cable (not included) to the **PC/DVI AUDIO IN** jack on the back of your TV and to the **AUDIO OUT** jack on the cable or satellite box.

Note
When you connect the audio using the **PC/DVI AUDIO IN** jack, the audio output is analog.

- 6 Turn on your TV, then turn on the cable or satellite box.
- 7 Go through the setup wizard on page 18.

Using component video (better)

To connect a cable or satellite box using component video:

- 1 Turn off your TV and all connected equipment.
- 2 Connect the incoming cable from the cable wall jack to the cable-in jack on the cable box.
- 3 Connect a component video cable (not included) to the **Y, PB,** and **PR** jacks on the side of your TV and the component video out jacks on the cable or satellite box.

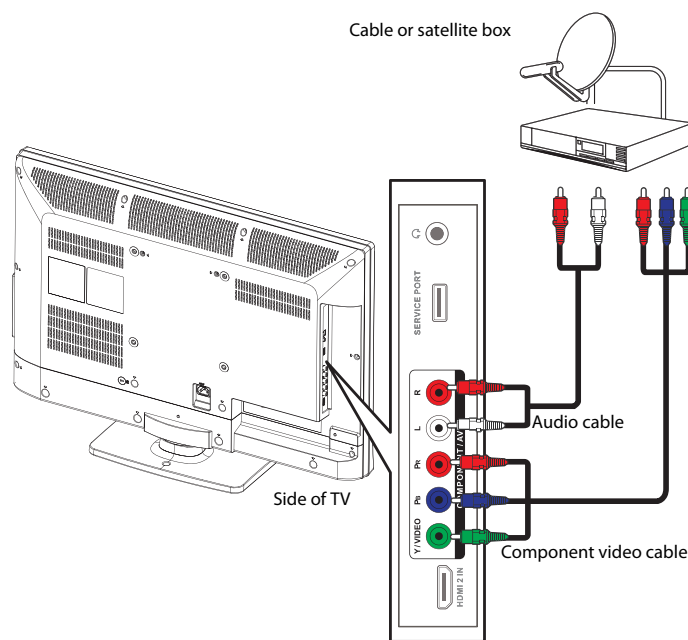

- 4 Connect an audio cable (not included) to the **L** and **R** audio jacks on the side of your TV and to the audio out jack on the cable or satellite TV box.

Note
When you connect the audio using the **L** and **R** audio jacks, the audio output is analog. Your TV has a digital audio jack, so you can connect the video to the component video jacks and connect the audio to the digital audio jack to get digital audio output.

- 5 Turn on your TV, then turn on the cable or satellite box.
- 6 Go through the setup wizard on page 18.

Using composite video (good)**To connect a cable or satellite box using composite video:**

- 1 Turn off your TV and all connected equipment.
- 2 Connect the incoming cable from the cable wall jack to the cable-in jack on the cable box.
- 3 Connect a composite cable (included) to the **Y/VIDEO**, **L**, and **R** jacks on the side of your TV and to the composite video and audio out jacks on the cable or satellite box.

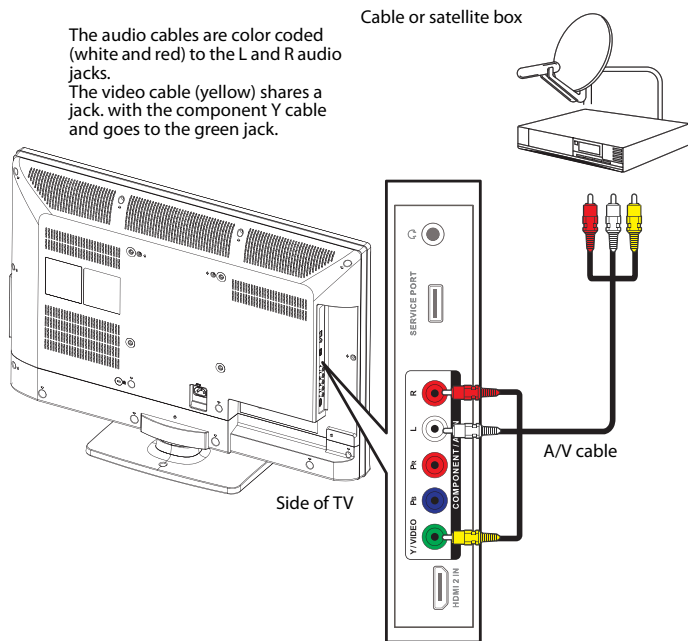

- 4 Turn on your TV, then turn on the cable or satellite box.
- 5 Go through the setup wizard on page 18.

Using coaxial (good)**To connect a cable or satellite box using coaxial:**

- 1 Turn off your TV and all connected equipment.
- 2 Connect the incoming cable from the cable wall jack to the cable-in jack on the cable or satellite box.
- 3 Connect a coaxial cable (not included) to the **ANT/CABLE IN** jack on the back of your TV and to the coaxial out jack on the cable or satellite box.

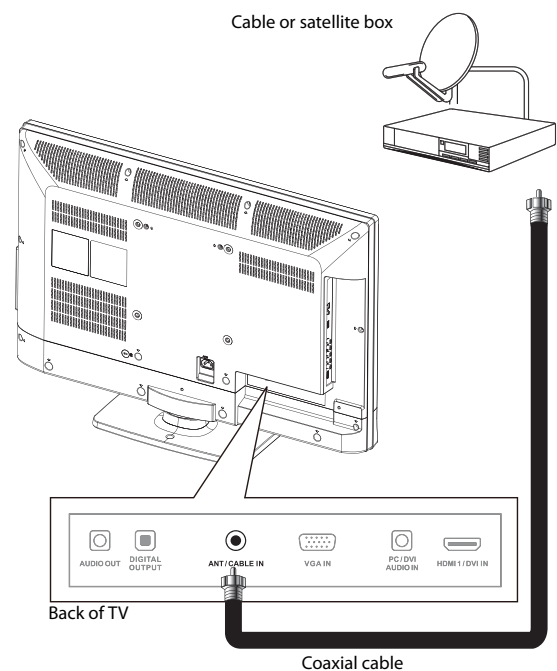

- 4 Turn on your TV, then turn on the cable or satellite box.
- 5 Go through the setup wizard on page 18.

Notes

- Use a coaxial cable to eliminate interference and noise from radio waves.
- Do not bundle the coaxial cable with the power cord or other cables.

Connecting an antenna or cable TV (no box)

To connect an antenna or cable TV (no box):

- 1 Turn off your TV and all connected equipment.
- 2 Connect a coaxial cable to the **ANT/CABLE IN** jack on the back of your TV and to the antenna or cable TV wall jack.

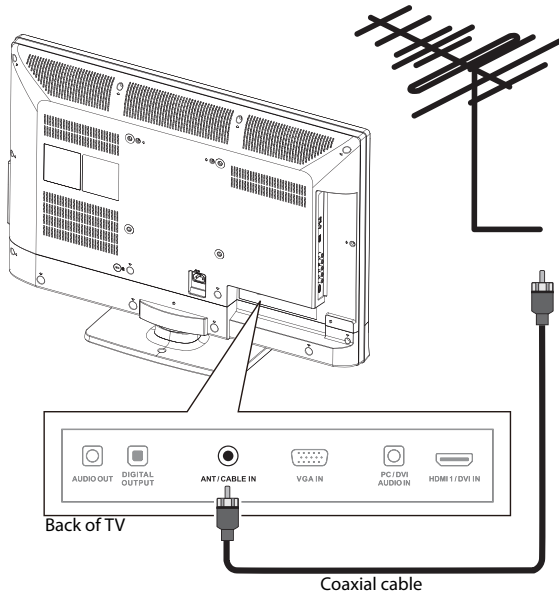

- 3 Turn on your TV.
- 4 Go through the setup wizard on page 18.

Notes

- Use a coaxial cable to eliminate interference and noise from radio waves.
- Do not bundle the coaxial cable with the power cord or other cables.
- If the antenna is not installed correctly, contact qualified service personnel to correct the problem.

Connecting a DVD or Blu-ray player

Using HDMI (best)

To connect a DVD or Blu-ray player using HDMI:

- 1 Make sure that your TV's power cord is unplugged and the DVD or Blu-ray player is turned off.
- 2 Connect an HDMI cable (not included) to an **HDMI** jack on the back of your TV and to the **HDMI OUT** jack on the DVD or Blu-ray player.

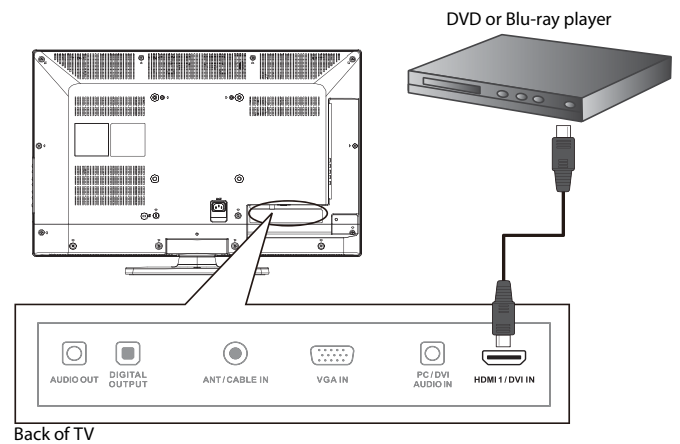

- 3 Turn on your TV, then turn on the DVD or Blu-ray player.
- 4 Press **INPUT** to open the *Input Source* list.
- 5 Press **▲** or **▼** to highlight **HDMI 1** or **HDMI 2**, then press **ENTER**.

Note

You can also press **HDMI** repeatedly to select the DVD or Blu-ray player.

Using DVI (same as HDMI but requires an audio connection)

Note

A DVI device must be connected the **HDMI 1** jack. If you connect a DVI device to another **HDMI** jack, you will not hear audio.

To connect a DVD or Blu-ray player using DVI:

- 1 Make sure that your TV's power cord is unplugged and the DVD or Blu-ray player is turned off.
- 2 Connect an HDMI-DVI adapter (not included) to one end of an HDMI cable (not included).
- 3 Connect the HDMI-DVI adapter to the **HDMI 1** jack on the back of your TV and to the **DVI OUT** jack on the DVD or Blu-ray player.

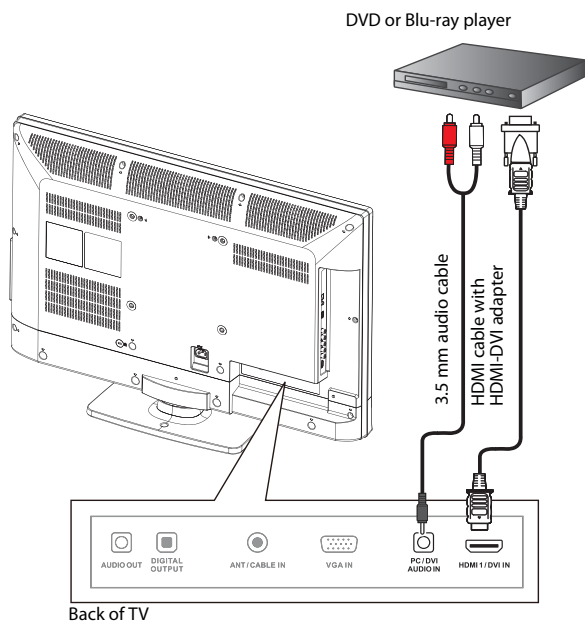

- 4 Connect an audio cable with a 3.5 mm stereo mini-jack (not included) to the **PC/DVI AUDIO IN** jack on the back of your TV and to the **AUDIO OUT** jack on the DVD or Blu-ray player.

Note

When you connect the audio using the **PC/DVI AUDIO IN** jacks, the audio output is analog. Your TV has a digital audio jack, so you can connect the video to the component video jacks and connect the audio to the digital audio jack to get digital audio output.

- 5 Turn on your TV.
- 6 Turn on the DVI device, then set it to the output mode. See the documentation that came with the device for more information.
- 7 Press **INPUT** to open the *Input Source* list.
- 8 Press **▲** or **▼** to highlight **HDMI 1**, then press **ENTER**.

Note

You can also press **HDMI** repeatedly to select the **HDMI 1**.

Using component video (better)

To connect a DVD or Blu-ray player using component video:

- 1 Make sure that your TV's power cord is unplugged and the DVD or Blu-ray player is turned off.
- 2 Connect a component video cable (not included) to the **Y/Pb/Pr** (component video) jacks on the side of your TV and to the **COMPONENT OUT** jacks on the component video device.

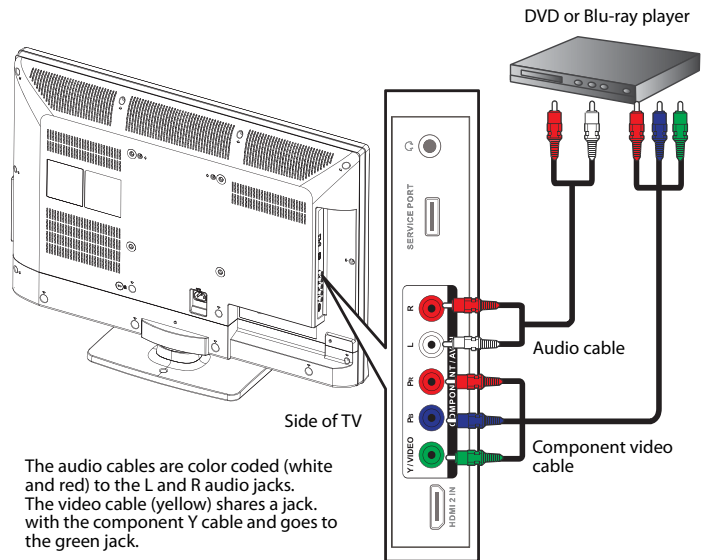

The audio cables are color coded (white and red) to the L and R audio jacks. The video cable (yellow) shares a jack with the component Y cable and goes to the green jack.

- 3 Connect an audio cable (not included) to the **L/R** (audio in) jacks on the side of your TV and to the **L/R AUDIO OUT** jacks on the component video device.

Notes

The **Y/Pb/Pr** (component video) jacks shares the audio jacks with the **CVBS** jacks. When you connect the audio using the **L** and **R** audio jacks, the audio output is analog. Your TV has a digital audio jack, so you can connect the video to the component video jacks and connect the audio to the digital audio jack to get digital audio output.

- 4 Turn on your TV, then turn on the DVD or Blu-ray player.
- 5 Press **INPUT** to open the *Input Source* list.
- 6 Press **▲** or **▼** to select **Component/AV**, then press **ENTER**.

Note

You can also press **COMP** to select the component DVD or Blu-ray player.

Using composite video (good)

To connect a DVD or Blu-ray player using composite video:

- 1 Make sure that your TV's power cord is unplugged and the DVD or Blu-ray player is turned off.
- 2 Connect a composite cable (included) to the **Y/VIDEO** and **L/R** (audio in) jacks on the side of your TV and to the **AV OUT** jacks on the DVD or Blu-ray player.

Note

When you connect the audio using the **L** and **R** audio jacks, the audio output is analog.

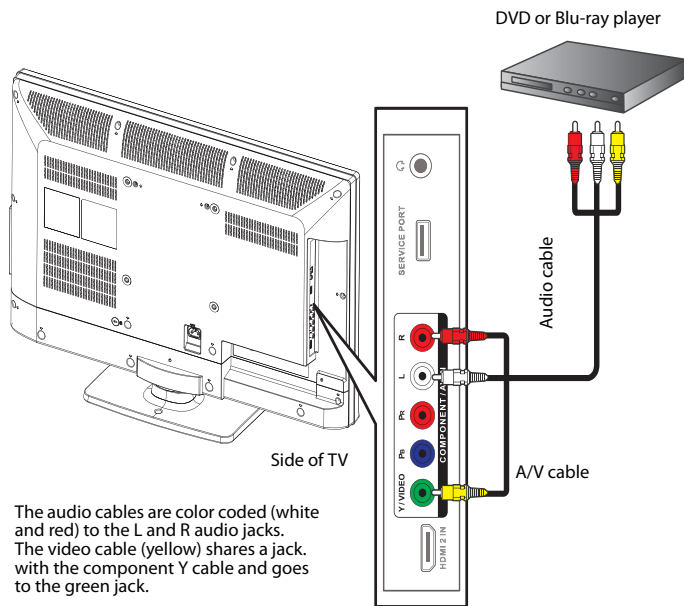

The audio cables are color coded (white and red) to the L and R audio jacks. The video cable (yellow) shares a jack with the component Y cable and goes to the green jack.

- 3 Turn on your TV, then turn on the DVD or Blu-ray player.
- 4 Press **INPUT** to open the *Input Source* list.
- 5 Press **▲** or **▼** to select **Component/AV**, then press **ENTER**.

Notes

- You can also press **VIDEO** to select the DVD or Blu-ray player.
- If you are not using the included audio cable for another device, you can use it and a standard one-plug video cable instead of the three-plug cable shown in this task.
- The **Y/Video** jack shares the audio jacks with the **Y/Pb/Pr** (component video) jacks.

Connecting a VCR

To connect a VCR:

- 1 Make sure that your TV's power cord is unplugged and the VCR is turned off.
- 2 Connect a composite cable (included) to the **Y/VIDEO** and **L/R** (audio in) jacks on the side of your TV and to the **AV OUT** jacks on the VCR.

Note

When you connect the audio using the **L** and **R** audio jacks, the audio output is analog.

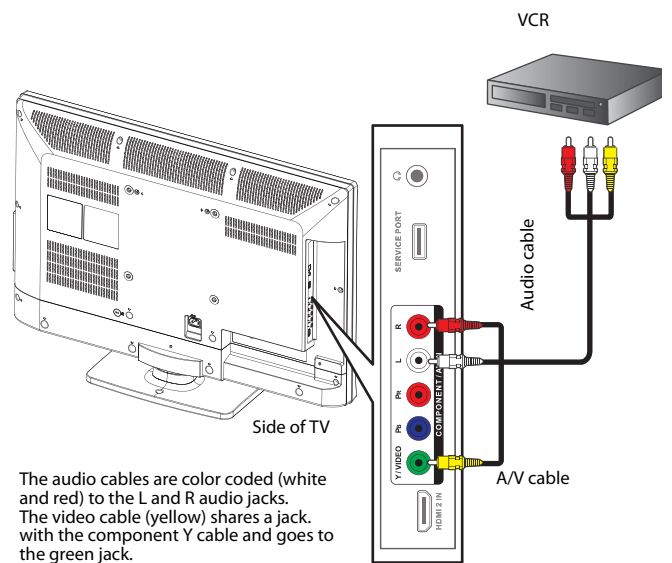

The audio cables are color coded (white and red) to the L and R audio jacks. The video cable (yellow) shares a jack with the component Y cable and goes to the green jack.

- 3 Turn on your TV, then press **INPUT** to open the *Input Source* list.
- 4 Press **▲** or **▼** to select **Component/AV**, then press **ENTER**.

Note

You can also press **VIDEO** to select the VCR.

- 5 Turn on the VCR, insert a videotape, then press **PLAY** on the VCR.

Note

The **Y/Video** jack shares the audio jacks with the **Y/Pb/Pr** (component video) jacks.

Connecting a camcorder or game console

Note

If your camcorder or game console has an HDMI connection, we recommend that you use the HDMI connection to get the best quality possible.

To connect a camcorder or game console:

- 1 Make sure that your TV's power cord is unplugged and the camcorder or game console is turned off.
- 2 Connect a composite cable (included) to the **Y/VIDEO** and **L/R** (audio in) jacks on the side of your TV and to the **AV OUT** jacks on the camcorder or game console.

Note

When you connect the audio using the L and R audio jacks, the audio output is analog.

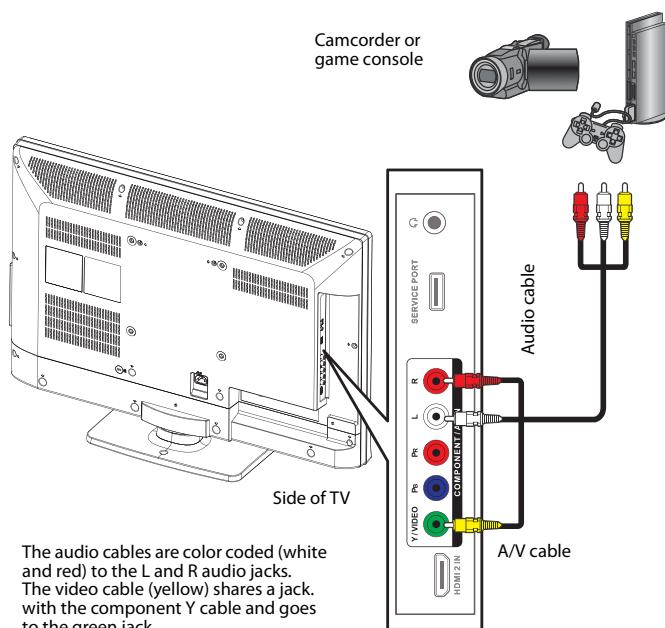

- 3 Turn on your TV, then press **INPUT** to open the *Input Source* list.
- 4 Press **▲** or **▼** to select **Component/AV**, then press **ENTER**.

Notes

- You can also press **VIDEO** to select the camcorder or game console.
- The **Y/Video** jack shares the audio jacks with the **Y/Pb/Pr** (component video) jacks.

Connecting a computer

Tip

Some computers have an HDMI jack. You can use an HDMI cable to connect the computer for a better picture.

Using VGA

To connect a computer using VGA:

- 1 Make sure that your TV's power cord is unplugged and the computer is turned off.
- 2 Connect a VGA cable (not included) to the **VGA IN** jack on the back of your TV and to the **VGA** jack on the computer.

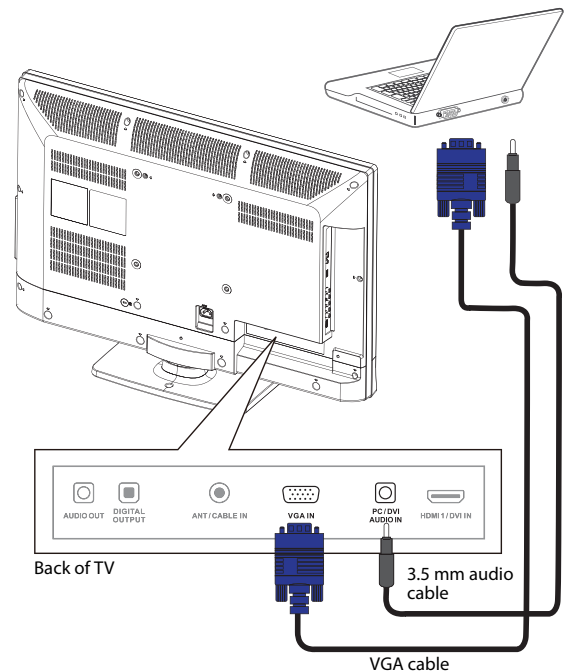

- 3 Connect an audio cable with 3.5 mm stereo mini plug to the **PC/DVI AUDIO IN** jack on the back of your TV and to the **LINE OUT** or **AUDIO OUT** jack on the computer.
- 4 Turn on your TV, then turn on the computer.
- 5 Press **INPUT** to open the *Input Source* list.
- 6 Press **▲** or **▼** to select **VGA**, then press **ENTER**.
- 7 Adjust the display properties on the computer if necessary.

Using HDMI

To connect a computer using HDMI:

- 1 Make sure that your TV's power cord is unplugged and the computer is turned off.
- 2 Connect an HDMI cable (not included) to an **HDMI** jack on the side of your TV and to the **HDMI OUT** jack on the computer player.

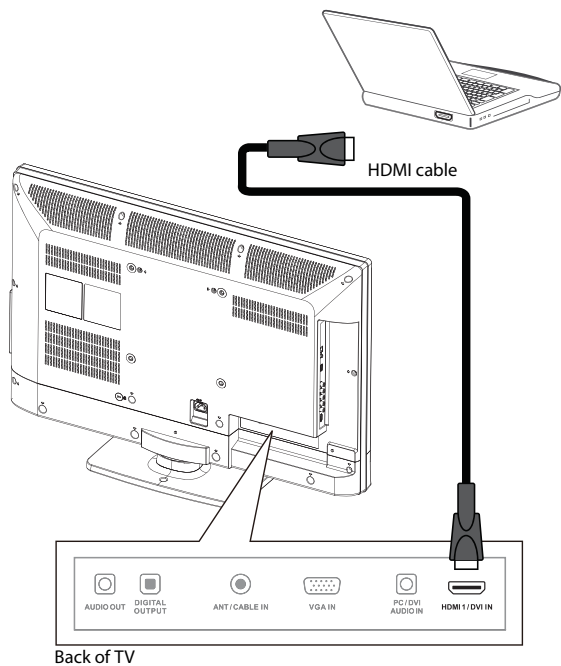

- 3 Turn on your TV, then turn on the computer.
- 4 Press **INPUT** to open the *Input Source* list.
- 5 Press **▲** or **▼** to select **HDMI 1** or **HDMI 2**, then press **ENTER**.

Note

You can also press **HDMI** repeatedly to select the computer.

Connecting headphones

The TV speakers are muted when headphones are attached.

Warning

Loud noise can damage your hearing. When using headphones, use the lowest volume setting on your headphones that still lets you hear the sound.

To connect headphones:

- Connect headphones to the  (headphone) jack on the side of your TV.

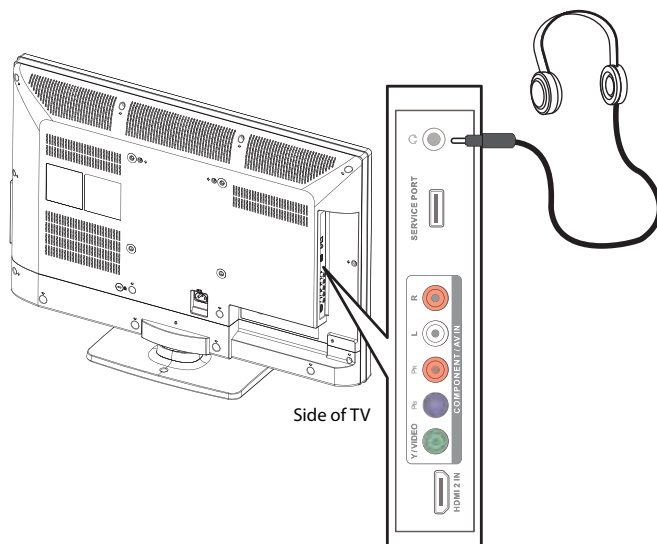

Connecting a basic home theater system

Using digital audio

To connect a basic home theater system using digital audio:

- 1 Make sure that your TV's power cord is unplugged and the home theater system is turned off.
- 2 Connect a digital optical audio cable to **DIGITAL OUTPUT** jack on the back of your TV and to the digital optical audio jack on the digital home theater system.

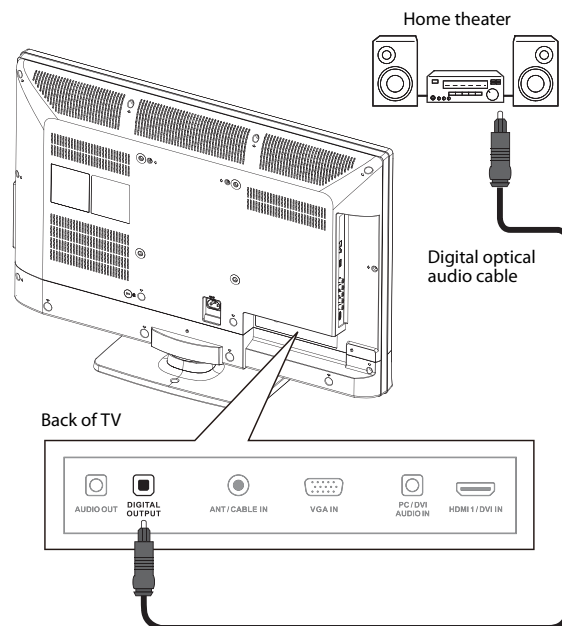

Using analog audio

To connect a basic home theater system using analog audio:

- 1 Make sure that your TV's power cord is unplugged and the home system is turned off.
- 2 Connect an audio cable to the **AUDIO OUT** jacks on the back of your TV and to the **AUDIO IN** jacks on the home theater system.

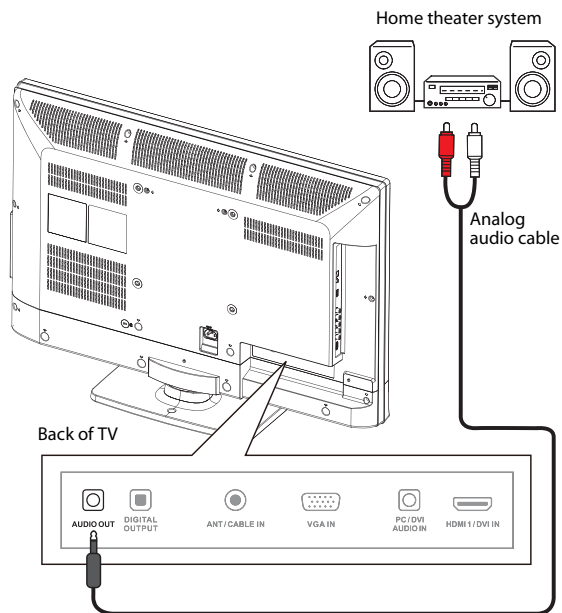

Connecting a home theater system with multiple devices

Note

We recommend that you connect the AV receiver's **HDMI OUT** jack to your TV's **HDMI1/DVI IN** jack, and AV receiver's **Audio IN** to your TV's **Digital Output** jack.

- Have a game console connected to your TV's **HDMI2 IN** jack.
- When you watch a program through an antenna or cable TV connected to the **ANT/CABLE IN** jack.

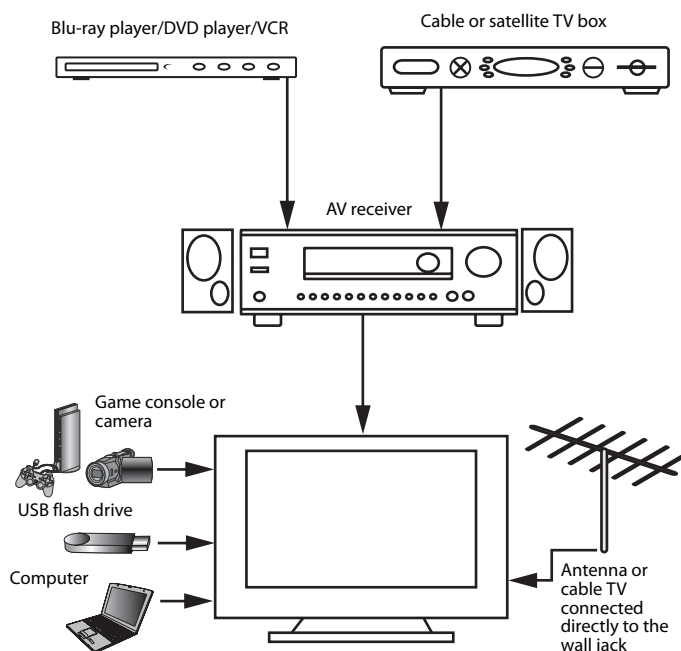

The connections you make depend on the video and audio jacks available on your devices. Refer to the documentation that came with your devices for connection information.

Just remember to use the best connection types available for the best picture and sound. For information about connection types, see "What connection should I use?" on page 7.

Using the remote control

Installing remote control batteries

To install the remote control batteries:

- 1 Remove the battery cover.
- 2 Insert two AAA batteries into the battery compartment. Make sure that you match the + and – symbols on the batteries with the + and – symbols in the battery compartment.

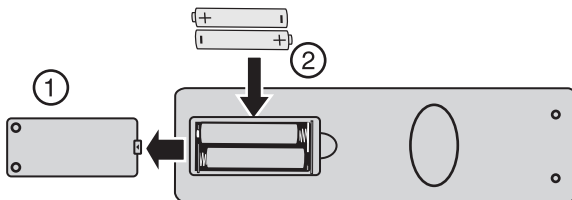

- 3 Replace the battery cover.

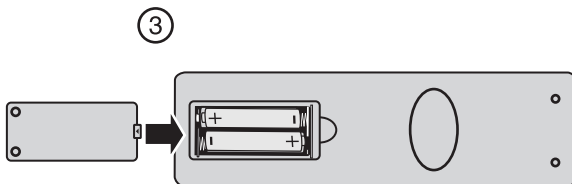

Cautions

- Batteries should not be exposed to excessive heat, such as sunshine, heat registers, or fire.
- Battery chemicals can cause a rash. If the batteries leak, clean the battery compartment with a cloth. If chemicals touch your skin, wash immediately.
- Make sure that batteries are disposed of correctly. Do not burn or incinerate.

Aiming the remote control

To aim the remote control:

- Point the remote control towards the remote sensor on the front of your TV.

Turning on your TV for the first time

The first time you turn on your TV, the Setup Wizard opens. The Setup Wizard guides you through setting up basic settings including the menu language, time setting, picture mode, TV signal source, and the channel list.

To set up your TV:

- 1 Make sure that you have:
 - Installed the remote control batteries. (See page 17 for details).
 - Connected an antenna, cable TV, or satellite TV. (See page 8 or 11 for details.)
 - Connected the power cord. (See page 8 for details.)
- 2 Press **⏻** (power) to turn on your TV. The *Choose Your Menu Language* screen opens.



- 3 Press **▲** or **▼** to highlight the language you want, then press **ENTER**. The *Choose Your Time Setting* screen opens.

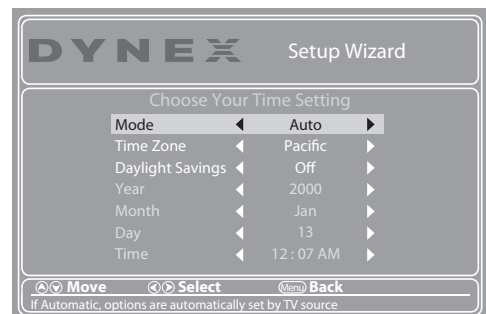

- 4 Press **▲** or **▼** to highlight **Mode**, then press **◀** or **▶** to select **Manual** (to set the date and time manually) or **Auto** (to set the date and time automatically from a TV signal source based on the time zone you select).
- 5 Press **▲** or **▼** to highlight **Time Zone**, then press **◀** or **▶** to select your time zone. You can select **Pacific, Alaska, Hawaii, Newfoundland, Atlantic, Eastern, Central, or Mountain**.
- 6 Press **▲** or **▼** to highlight **Daylight Savings**, then press **◀** or **▶** to select **On** (if your viewing area observes Daylight Savings Time) or **Off** (if your viewing area does not observe Daylight Savings Time).
- 7 If you selected **Manual** for **Mode**, set the date by pressing **▲** or **▼** to highlight **Time Zone, Daylight Savings, Year, Month, or Day**, then press **◀** or **▶** to adjust the setting.
- 8 If you selected **Manual** for **Mode**, set the time by pressing **▲** or **▼** to highlight **Time**, then pressing **◀** or **▶** to select the hour, minute, or AM/PM field. Press **▲** or **▼** to adjust the setting.

- 9 Press **ENTER**. The *Choose Your Picture Mode* screen opens.



- 10 Press **▲** or **▼** to highlight **Home Mode** or **Retail Mode**, then press **ENTER**.
If you selected **Retail Mode**, a message appears, asking "Are you sure you want retail mode?" Select **Yes** to continue, or select **No** to change your selection.
The *Choose Your TV source* screen opens.

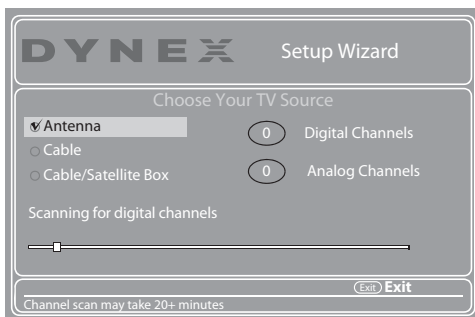

- 11 Press **▲** or **▼** to highlight **Antenna**, **Cable**, or **Cable/Satellite Box** (if your cable TV uses a box, select **Cable/Satellite Box**), then press **ENTER**. If you chose **Antenna** or **Cable**, your TV automatically starts scanning for channels available in your viewing area. If you chose **Cable/Satellite box**, your TV does not need to scan for channels.

During auto channel search, your TV searches for digital channels first. When the digital channel search is complete, a message appears asking if you want to search for analog channels. Select **Yes** to continue searching for analog channels, or select **No** to stop searching for channels.

- 12 To watch TV, press **INPUT**, press **▲** or **▼** to highlight the video input source for your TV in the *INPUT SOURCE* list, then press **ENTER**.
- If your TV is connected to an antenna, cable TV (no box), or cable or satellite TV box using a coaxial cable, select **TV**.
 - If your TV is connected to a cable or satellite box using an HDMI cable or HDMI cable with a DVI adapter, select **HDMI 1** or **HDMI 2**.
 - If your TV is connected to a cable or satellite box using a component video cable, select **Component**.
 - If your TV is connected to a cable or satellite box using a composite video cable, select **AV**.

Understanding the basics

Turning your TV on or off

To turn your TV on or off:

- 1 Make sure that the power cord is connected to a power outlet.
- 2 Press **⏻** (power) to turn on your TV. The power indicator LED turns off.
- 3 Press **⏻** (power) again to turn off your TV. Your TV enters Standby mode and the power indicator LED turns red.

Selecting the video input source

To select the video input source:

- 1 Turn on your TV, then press **INPUT**. The *Input Source* list opens.

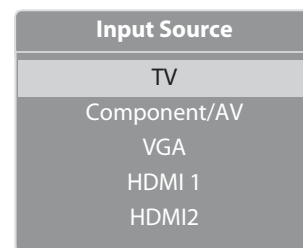

- 2 Press **▲** or **▼** to highlight a video input source, then press **ENTER**.

You can also press a direct input button to select the video input source.

- Press **TV** to select **TV**.
- Press **COMP** or **VIDEO** to select **Component/AV**.
- Press **HDMI** once to select **HDMI 1**. Press twice to select **HDMI 2**.
- Press **VGA** to select **VGA**.

Using the on-screen menus

Notes

- Depending on the signal source selected, you may see different options on your screen. The following menus are shown in TV mode (except the USB menu).
- Menu items that are not selectable are grayed out.
- Menus in this manual are described in TV mode, unless otherwise indicated.
- The screens shown in this manual are for explanation purposes and may vary from the actual screens on your TV.

PICTURE menu (TV mode)

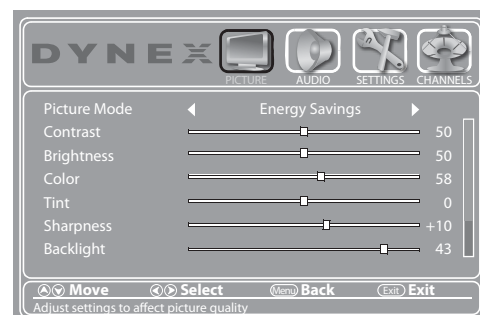

AUDIO menu (TV mode)

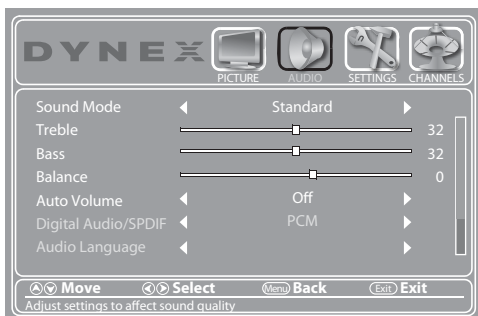

SETTINGS menu (TV mode)

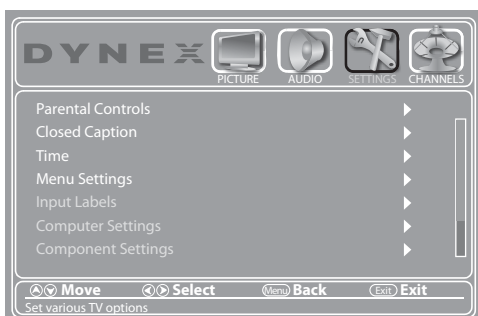

CHANNELS menu (TV mode)

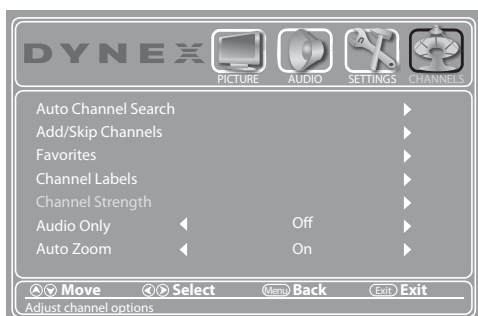

Navigating the menus

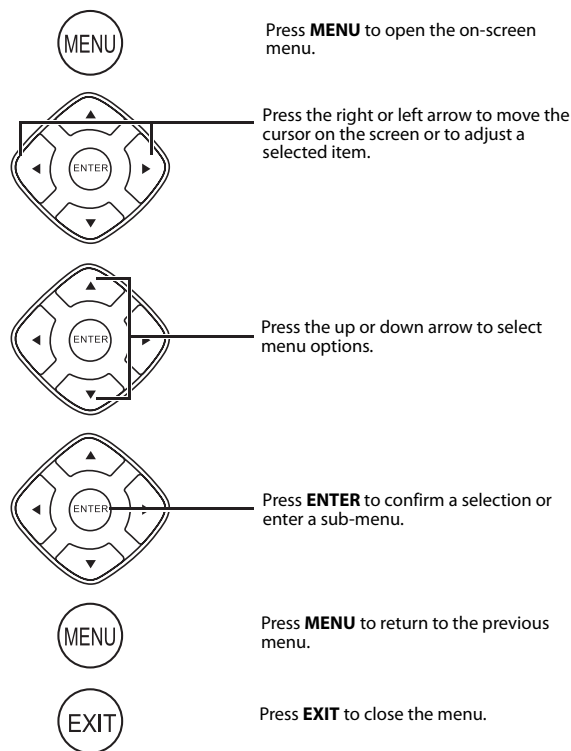

Selecting a channel

To select a channel:

- Press **CH+** or **CH-** to go to the next or previous channel on the memorized channel list.
- Press the number buttons to enter the channel number you want, then wait for the channel to change or press **ENTER** to immediately change the channel.
- To select a digital sub-channel, press the number buttons to select the main digital channel, press **●** (dot), then press the number button for the sub-channel. Wait for the channel to change, or press **ENTER** to immediately change the channel. For example, to tune to channel 5.1, press **5**, **●** (dot), then **1**.
- Press **RECALL** to go to the last viewed channel.
- Press **CH-LIST** to open the channel list, press **▲** or **▼** to highlight a channel, then press **ENTER**. Hidden channels are grayed out in the channel list.
- Press **FAVORITE** to open the favorite channel list, press **▲** or **▼** to highlight a channel, then press **ENTER**.

Note

If a list has more than one page, press **▲** or **▼** to scroll through the pages.

Adjusting the volume

To adjust the volume:

- Press **VOL +** or **VOL -** to increase or decrease the volume.
- Press **MUTE** to turn off the sound. Press **MUTE** again to turn the sound back on.

Viewing channel information

To view channel information:

- Press **INFO** to view an information banner. The information banner shows the current program information such as channel number, video input source, and resolution.
 - Digital channel information—Displays the channel number, station name, channel label, broadcast program name, TV rating, signal type, audio information, resolution, CC mode, current time, and current program start and end times.
 - Analog channel information—Displays channel number, channel label (if preset), signal type, audio information, and resolution.
- Press **GUIDE** to show the digital program guide, which may view a list of available programs, program times, and program summaries, depending on the information provided by the broadcaster.

Adjusting the picture

Adjusting the TV picture

To adjust the TV picture:

- 1 Press **MENU**. The on-screen menu opens with the **PICTURE** menu displayed.

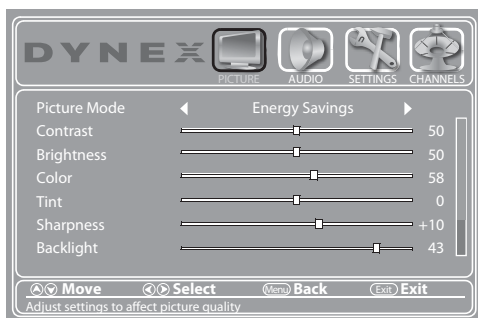

- 2 Press **▲** or **▼** to highlight an option, then press **◀** or **▶** to adjust the option. You can select:

- **Picture Mode**—Selects the picture mode. You can select:
 - **Vivid**—(a bright and vivid picture). Significantly increases the contrast, brightness, and sharpness. This selection is good for video games, animation, and in bright light environments.
 - **Standard**—(a standard picture). Moderately increase the contrast, brightness, and sharpness. This selection is good for standard TV broadcasts.
 - **Energy Savings**—(the backlight brightness is decreased). Your TV has a backlight that provides light for displaying a picture. By reducing the amount of light, your TV uses less energy.
 - **Custom**—(customized picture). Lets you manually adjust picture settings such as brightness, contrast, and sharpness.

Note

You can also press **PICTURE** to select the picture mode.

- **Contrast**—Adjusts the brightness of the light areas of the picture.
- **Brightness**—Adjusts the brightness of the dark areas of the picture.

- **Color**—Adjusts the color intensity of the picture. A low setting may make the color look faded. A high setting may make the color look artificial.
- **Tint**—Adjusts the color balance of the picture. Use this control to make skin tones look more natural.
- **Sharpness**—Adjusts the color detail of images. If you set this control too high, dark images may appear with light or white edges.
- **Backlight**—Sets the overall brilliance of the screen.
- **Advanced Video**—Opens the menu where you can adjust additional video options.
 - **Color Temperature**—Selects the color temperature. You can select **Cool** (to enhance the blues), **Normal**, or **Warm** (to enhance the reds).
 - **Aspect Ratio**—Selects the aspect ratio of the picture.

Aspect ratio option	Example
Normal: Displays the original aspect ratio with black bars vertical on the left and right sides of the screen.	
Zoom: Expands the image to fill the screen. The top and bottom of the image may be cropped.	
Wide: Use this option to view content recorded in a 16:9 (wide-screen) aspect ratio.	
Cinema: Stretches the image at the edges, but keeps a clear image in the center.	
Auto: Automatically adjusts the image based on the screen size and the TV program. Note: Auto is only available when Auto Zoom in the CHANNELS menu must be set to On .	

Note

You can also press **ZOOM** to select the aspect ratio.

- **Noise Reduction**—Selects the noise reduction mode to reduce picture noise (snow). You can select **Low**, **Middle**, **Strong**, or **Off**.
- **Overscan**—Adjusts the picture's reproduction rate. You can select **On** or **Off**.
- **Advanced Contrast**—Selects from **Adaptive Contrast** or **Dynamic Contrast Ratio**.
 - **Adaptive Contrast**—Automatically adjusts picture detail and brightness. You can select **On** or **Off**.
 - **Dynamic Contrast Ratio**—Enhances the contrast ratio between light and dark areas of the picture. You can select **On** or **Off**.

- **Reset Picture Settings**—Resets all picture settings to factory mode.

- 3 Press **MENU** to return to the previous menu, or press **EXIT** to close the menu.

Adjusting the computer image

To adjust the computer image:

- 1 Make sure that your TV is in VGA mode. For more information, see “Selecting the video input source” on page 18.
- 2 Press **MENU**. The on-screen menu opens.

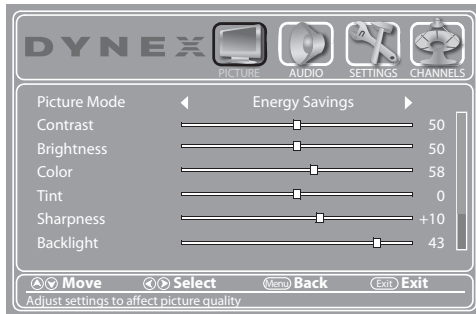

- 3 Press ◀ or ▶ to highlight **SETTINGS**, then press ▼. The **SETTINGS** menu opens.

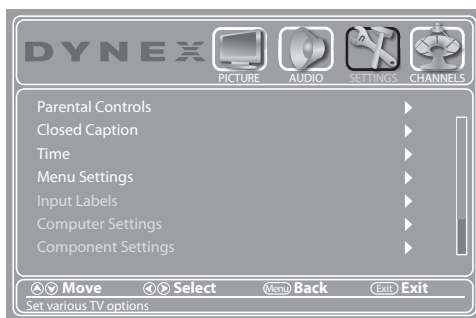

- 4 Press ▲ or ▼ to highlight **Computer Settings**, then press **ENTER**. The **SETTINGS-Computer Settings** menu opens.
- 5 Press ▲ or ▼ to highlight an option, then press ◀ or ▶ to adjust the option. You can select:
 - **Auto Adjust**—Automatically adjusts the image settings such as position and phase.
 - **H. Position**—Moves the image right or left.
 - **V. Position**—Moves the image up or down.
 - **Clock**—Adjusts the sample frequency.
 - **Phase**—Adjusts the focus of stable images.
 - **Reset Computer Settings**—Resets all computer settings to factory mode.
- 6 Press **MENU** to return to the previous menu, or press **EXIT** to close the menu.

Adjusting the sound

Adjusting sound settings

To adjust sound settings:

- 1 Press **MENU**. The on-screen menu opens.

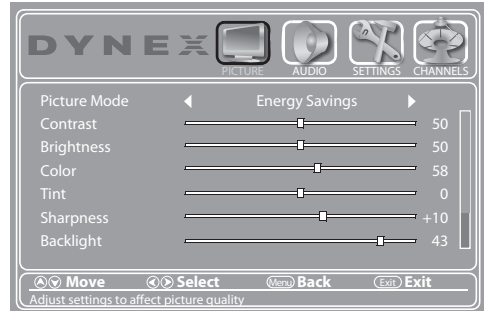

- 2 Press ◀ or ▶ to highlight **AUDIO**, then press ▼. The **AUDIO** menu opens.

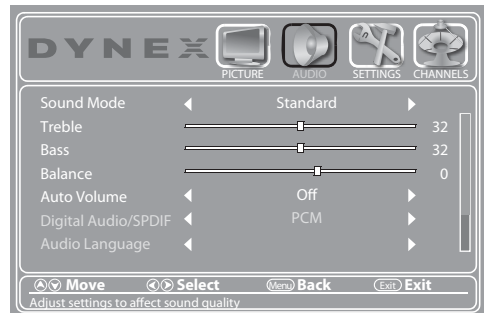

- 3 Press ▲ or ▼ to highlight an option, then press ◀ or ▶ to adjust the option. You can select:
 - **Sound Mode**—Selects the picture mode. You can select **Movie**, **Music**, **News**, **Standard**, or **Custom**.
 - **Treble**—Adjusts the high sounds.
 - **Bass**—Adjusts the low sounds.
 - **Balance**—Adjusts the balance between the left and right audio channels.
 - **Auto Volume**—Automatically adjusts volume to be consistent across programs and channels.
 - **Digital Audio/SPDIF**—Sends digital audio to an external audio system. You can select **PCM** (to select to output audio in 2-channel stereo), or **RAW** (to pass through the original digital audio sound).
 - **Audio Language**—(Digital channels only) Selects an alternate audio language, if available.
 - **MTS/SAP**—(Analog channels only) Selects the audio mode. You can select:
 - **Mono**—Select this option if there is noise or static on weak stereo broadcasts.
 - **Stereo**—Select this option for programs broadcast in stereo.
 - **SAP**—Select this option to listen to a secondary audio program, if available.

Note

You can also press **MTS/SAP** one or more times to select the audio mode.

- **Reset Audio Settings**—Resets all audio settings to factory defaults.
- 4 Press **MENU** to return to the previous menu, or press **EXIT** to close the menu.

Playing TV audio only

You can turn off the picture on your TV and listen to the program audio only.

To play TV audio only:

- 1 Press **MENU**. The on-screen menu opens.

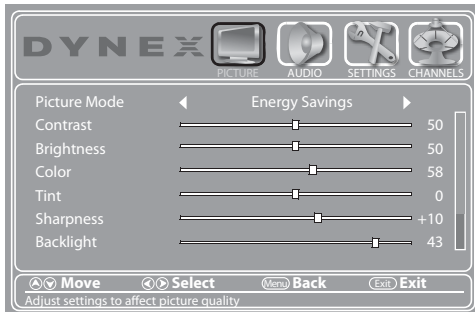

- 2 Press **◀** or **▶** to highlight **CHANNELS**, then press **▼**. The **CHANNELS** menu opens.



- 3 Press **▲** or **▼** to highlight **Audio Only**, then press **ENTER**.
- 4 Press **◀** or **▶** to select **On**.
- 5 Press **MENU** to return to the previous menu, or press **EXIT** to close the menu. The picture turns off in approximately 3 to 5 seconds.

Notes

- Audio Only works only when the input source is TV and your TV is receiving a broadcast signal.
- To exit Audio Only mode, press any button. When you exit Audio Only mode, the Audio Only option is automatically reset to Off.

Changing channel settings

Automatically scanning for channels

When you scan for channels, your TV searches for channels with signals and stores the channel information in the channel list. When you press **CH +** or **CH -**, your TV goes to the next or previous channel in the channel list.

If the TV signal source changes, for example you change from an outdoor antenna to cable TV (no box), you need to scan for channels.

To automatically scan for channels:

- 1 Press **MENU**. The on-screen menu opens.

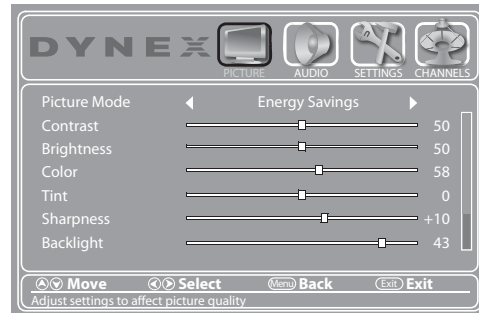

- 2 Press **◀** or **▶** to highlight **CHANNELS**, then press **▼**. The **CHANNELS** menu opens.



- 3 Press **▲** or **▼** to highlight **Auto Channel Search**, then press **ENTER**. The **CHANNELS-Choose Your TV Source** screen opens.

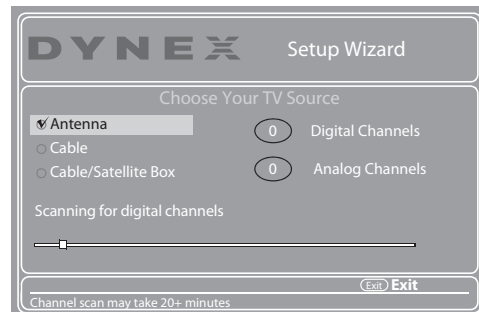

- 4 Press **▲** or **▼** to highlight **Antenna**, **Cable**, or **Cable/Satellite Box**, then press **ENTER**.

- If you are using an antenna for a standard or HD TV signal, select **Antenna**.
- If your cable is connected directly to the TV (using no tuner box), select **Cable**.
- If your cable is connected to your TV through a tuner box, select **Cable/Satellite Box**.
- If you selected **Antenna** or **Cable**, your TV searches automatically for available channels in your area and stores the channel information in the channel list. This may take several minutes. While searching, the TV displays a progress report.

Or,

If you selected **Cable/Satellite Box**, the channel search is not necessary.

Note

You can press **EXIT** to stop the auto channel search, but you will need to run the auto channel search again to create a channel list.

Hiding channels

You can hide channels in the channel list. When you press **CH+** or **CH-**, your TV skips the hidden channels. You can still tune to a hidden channel by pressing the number buttons for the channel.

To hide channels:

- 1 Press **MENU**. The on-screen menu opens.

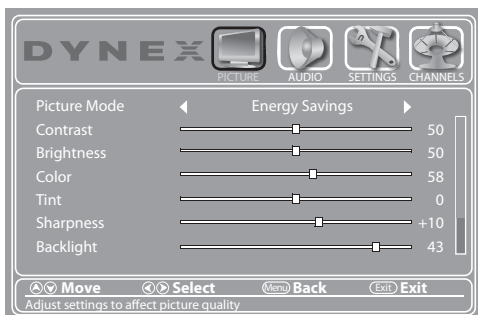

- 2 Press **◀** or **▶** to highlight **CHANNELS**, then press **▼**. The **CHANNELS** menu opens.

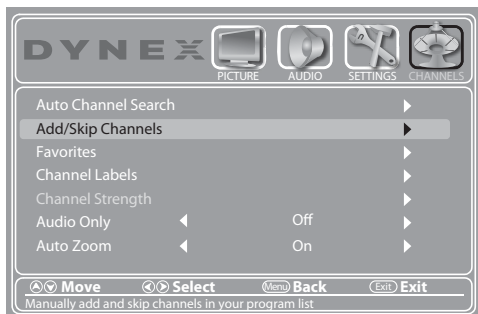

- 3 Press **▲** or **▼** to highlight **Add/Skip Channels**, then press **ENTER**. The **Channels list** opens.

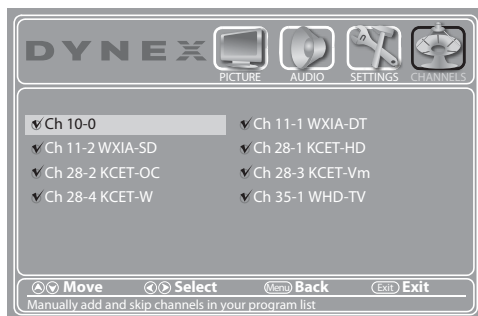

- 4 Press **▲** or **▼** to highlight the channel you want to hide, then press **ENTER**. The check mark disappears.

Notes

- A channel with a check mark is not hidden. A channel with no check mark is hidden.
- If the list has more than one page, press **▲** or **▼** to scroll through the pages.

- 5 Press **EXIT** to close the menu.

Setting up a favorite channel list

You can create a favorite channel list so you can quickly browse through your favorite channels by pressing **FAVORITE**, then selecting a channel from the favorite channel list.

To set up a favorite channel list:

- 1 Press **MENU**. The on-screen menu opens.

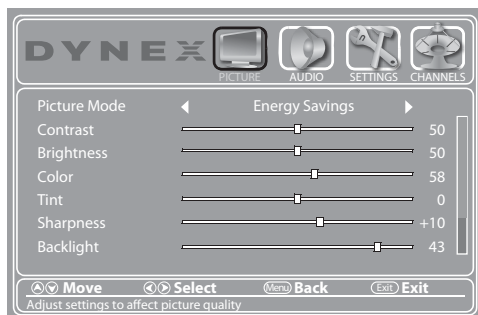

- 2 Press **◀** or **▶** to highlight **CHANNELS**, then press **▼**. The **CHANNELS** menu opens.

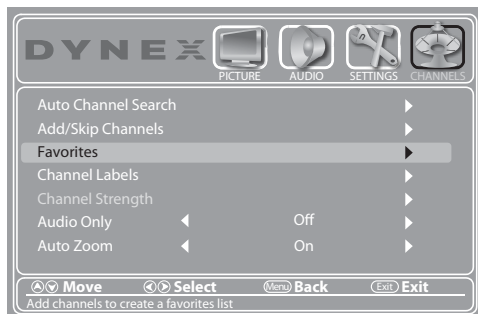

- 3 Press **▲** or **▼** to highlight **Favorites**, then press **ENTER**. The **CHANNELS-Favorites** screen opens.

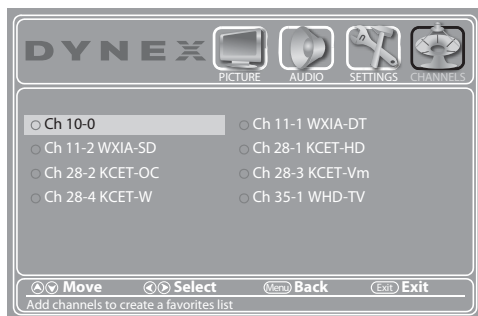

- 4 Press **▲** or **▼** to highlight the channel you want to add to the favorites list, then press **ENTER**. A check mark appears next to the channel.

Notes

- To remove a channel from the favorites list, highlight the channel, then press **ENTER**. The check mark disappears and the channel is removed from the list.
- If the list has more than one page, press **▲** or **▼** to scroll through the pages.

- 5 Press **EXIT** to close the menu.

Viewing a favorite channel

To view a favorite channel:

- 1 Press **FAVORITE**. The favorite channel list opens.
- 2 Press **▲** or **▼** to highlight a channel, then press **ENTER**.

Adding or changing a channel label

If a channel is not already labeled, you can label the channel to make it easier to identify. You can also relabel a channel that is already labeled.

To add or change a channel label:

- 1 Press **MENU**. The on-screen menu opens.

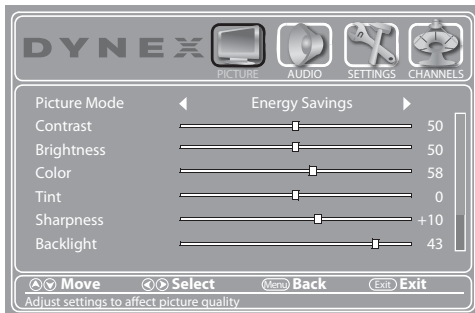

- 2 Press **◀** or **▶** to highlight **CHANNELS**, then press **▼**. The **CHANNELS** menu opens.

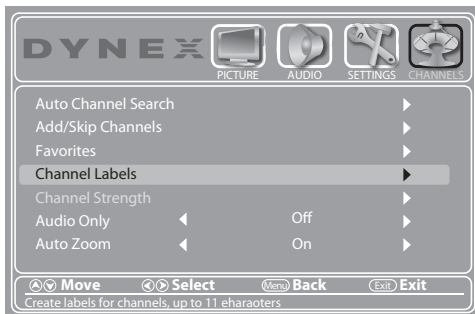

- 3 Press **▲** or **▼** to highlight **Channel Labels**, then press **ENTER**. The **Channel Labels** screen opens.

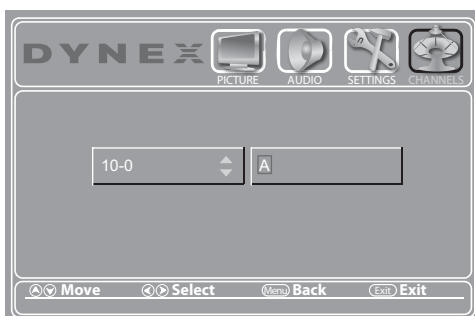

- 4 Press **▲** or **▼** to select the channel you want to label, then press **▶** to move to the channel label field.
- 5 Press **▲** or **▼** to select a character, then press **◀** or **▶** to move to the next position. Repeat this step to enter additional characters. You can enter as many as 11 characters. If you need to delete a character, press **◀** and if you want to enter a space, select the blank.
- 6 When you have completed the label, press **ENTER**.
- 7 Press **◀** or **▶** to choose **Yes** to confirm your new label.
- 8 Press **EXIT** to close the menu.

Checking the digital signal strength

You can check the digital signal strength to determine if you need to adjust your antenna or digital cable input. The higher the signal strength, the less likely you are to experience picture degradation.

To check the digital signal strength:

- 1 Press **MENU**. The on-screen menu opens.

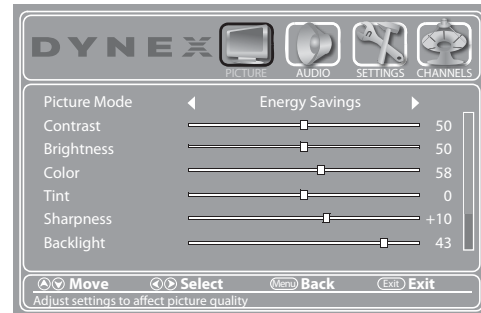

- 2 Press **◀** or **▶** to highlight **CHANNELS**, then press **▼**. The **CHANNELS** menu opens.

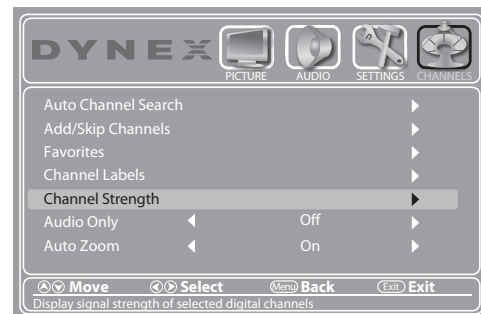

- 3 Press **▲** or **▼** to highlight **Channel Strength**, then press **ENTER**. The DTV signal strength is indicated by the color bar.
- 4 Press **EXIT** to close the menu.

Setting parental controls

Setting or changing the password

Parental controls let you prevent your children from watching inappropriate material on TV. When set, parental controls read the rating of the program (with some exceptions, such as news and sports) and deny access to programs that exceed the ratings level you select. To watch programs that exceed the selected rating, you must enter a password.

To set or change the password:

- 1 Press **MENU**. The on-screen menu opens.

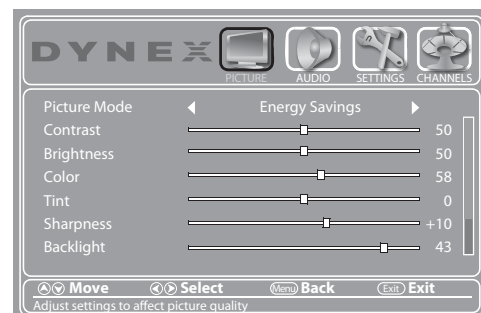

- Press **◀** or **▶** to highlight **SETTINGS**, then press **▼**. The **SETTINGS** menu opens with **Parental Controls** highlighted.

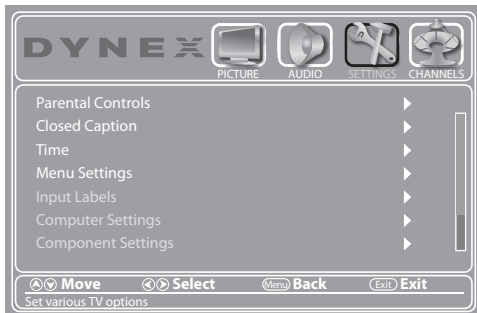

- Press **ENTER**. The *Enter Password* screen opens.



- Press the number buttons to enter the four-digit password. The default password is **0000**. You should change the password to a number you can remember. The *Parental Controls* menu opens.

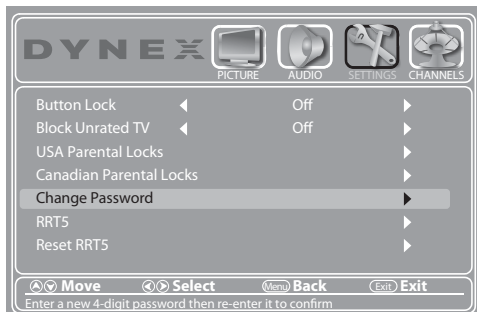

- Press **▲** or **▼** to highlight **Change Password**, then press **ENTER**. The password entry screen opens.

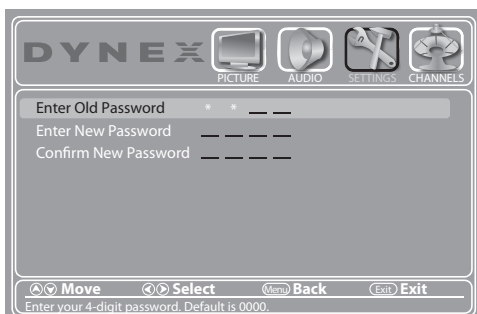

- Press the number buttons to enter a password, then enter the password again. The *Parental Controls* menu opens again.

Note
If you forget your password, enter **9999**.

- Press **EXIT** to close the menu.

Locking control buttons

When the button lock is turned **On**, the buttons on the side of your TV are locked and you can only operate your TV using the remote control.

To lock control buttons:

- Press **MENU**. The on-screen menu opens.

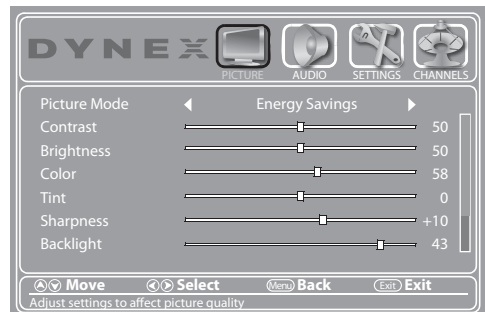

- Press **◀** or **▶** to highlight **SETTINGS**, then press **▼**. The **SETTINGS** menu opens with **Parental Controls** highlighted.

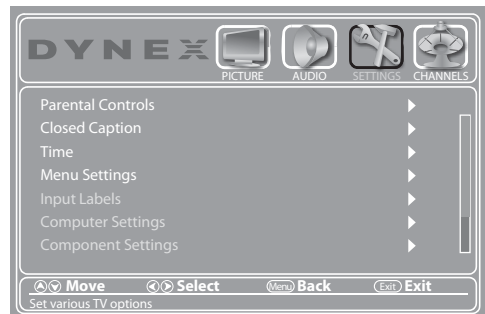

- Press **ENTER**. The *Enter Password* screen opens.



- Press the number buttons to enter the four-digit password. The menu opens with **Button Lock** highlighted.

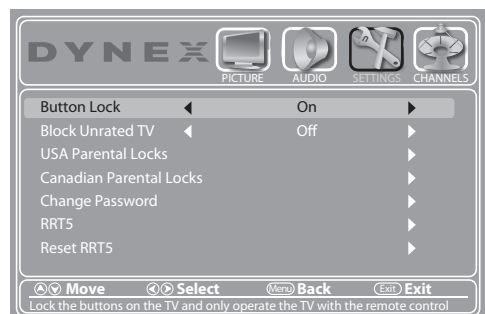

- Press **ENTER**.
- Press **▲** or **▼** to select **On** (locks the buttons) or **Off** (unlocks the buttons).
- Press **EXIT** to close the menu.

Setting parental control levels

You can set parental controls for the U.S. and Canada. The following task shows how to set controls for U.S. TV ratings. You use similar steps for setting U.S. movie and Canadian TV ratings.

To set parental control levels:

- 1 Press **MENU**. The on-screen menu opens.

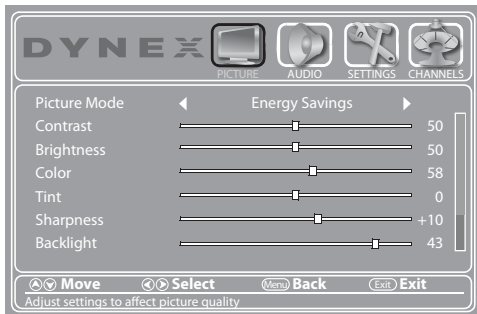

- 2 Press **◀** or **▶** to highlight **SETTINGS**, then press **▼**. The **SETTINGS** menu opens with **Parental Controls** highlighted.

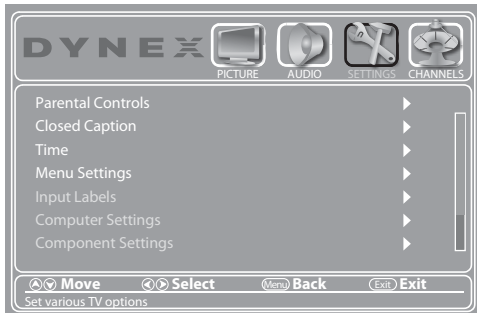

- 3 Press **ENTER**. The *Enter Password* screen opens.



- 4 Press the number buttons to enter the four-digit password. The **SETTINGS-Parental Controls** menu opens.



- 5 Press **▲** or **▼** to highlight **USA Parental Locks**, then press **ENTER**. (To set Canadian ratings, select **Canadian Parental Locks**.)

USA Parental Locks

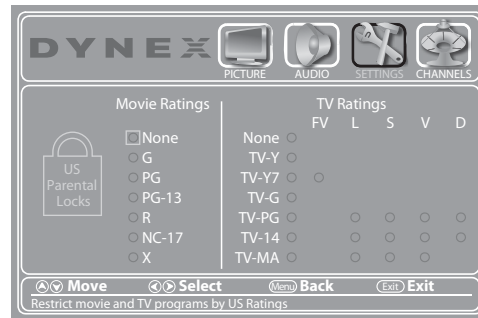

Canadian Parental Locks

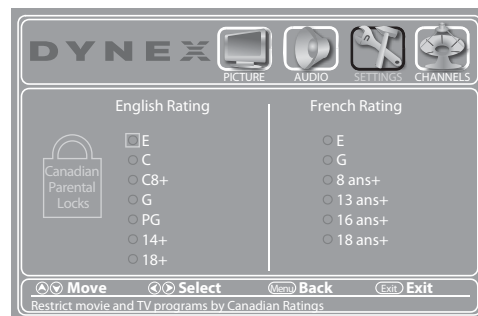

- 6 Press **◀** or **▶** to highlight:
 - **Movie Ratings** or **TV Ratings** for USA ratings.
 - **English Rating** or **French Rating** for Canadian ratings.
- 7 Press **▲** or **▼** to select the rating. If a rating has sub-ratings, press **◀** or **▶** to highlight a sub-rating.

Note

When you block a rating, that rating and all higher ratings are blocked.

- 8 Press **EXIT** to close the menu.

U.S. TV ratings (age-based)

NONE	Not rated
TV-Y	All children
TV-Y7	Children over seven years of age
TV-G	General audiences
TV-PG	Parental guidance suggested
TV-14	Parents strongly cautioned
TV-MA	Mature audiences only

Some of the age-based TV Parental Guidelines ratings also have content-based ratings.

U.S. TV content ratings

All	All ratings are blocked
FV	Fantasy violence
L	Adult language
S	Sexual situations
V	Violence
D	Sexually suggestive dialog

U.S. movie (MPAA) ratings	
None	Movie not rated
G	General audiences
PG	Parental guidance suggested
PG-13	Suitable for children 13 and older
R	Parental guidance suggested for children under 17
NC-17	Not suitable for children under 17
X	Adults only

Canadian English ratings	
E	Exempt programming
C	Children
C8+	Children over 8 years old
G	General audiences
PG	Parental guidance
14+	Over 14 years old
18+	Adult programming

Canadian French ratings	
E	Exempt programming
G	General audiences
8ans+	Over 8 years old
13ans+	Over 13 years old
16ans+	Over 16 years old
18ans+	Adult programming

Downloading rating information

You can download rating information to use when setting parental controls.

To download rating information:

- 1 Press **MENU**. The on-screen menu opens.

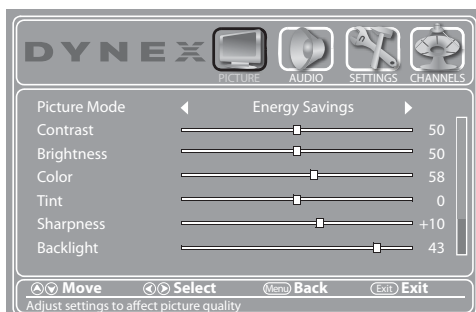

- 2 Press **◀** or **▶** to highlight **SETTINGS**, then press **▼**. The **SETTINGS** menu opens with **Parental Controls** highlighted.

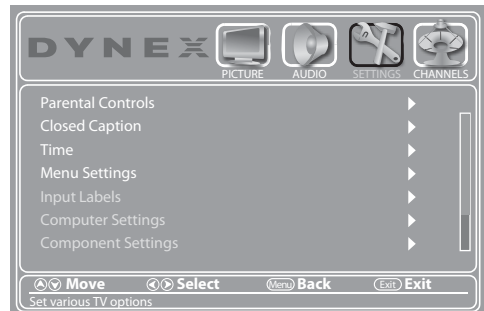

- 3 Press **ENTER**. The *Enter Password* screen opens.

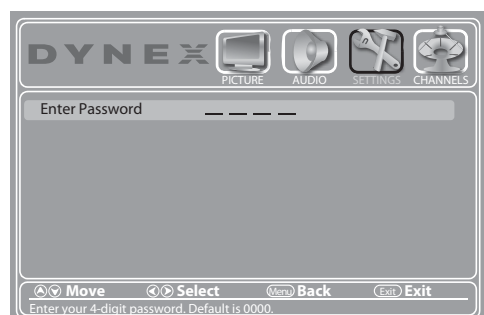

- 4 Press the number buttons to enter the four-digit password. The **SETTINGS-Parental Controls** menu opens.



- 5 Press **▲** or **▼** to highlight **RRT5**, then press **ENTER**. If the program is broadcast with RRT5 rating information, the information is downloaded automatically and can be used for parental controls.
- 6 Press **EXIT** to close the menu.

Using closed captioning

Turning closed captioning on or off

To turn closed captioning on or off:

- 1 Press **MENU**. The on-screen menu opens.

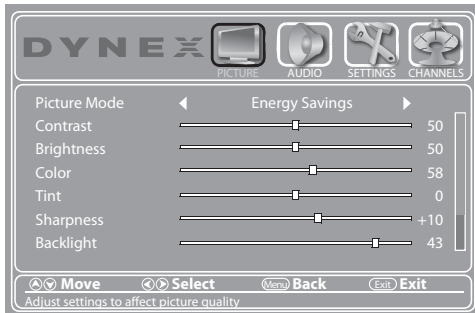

- 2 Press **◀** or **▶** to highlight **SETTINGS**, then press **▼**. The **SETTINGS** menu opens.

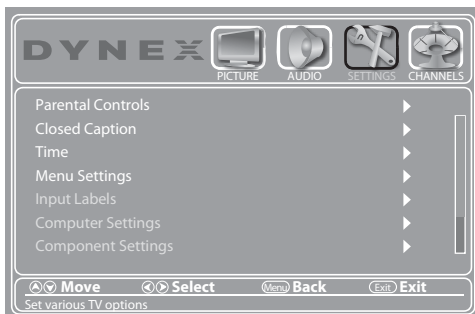

- 3 Press **▲** or **▼** to highlight **Closed Caption**, then press **ENTER**. The **SETTINGS-Closed Caption** menu opens.



- 4 Press **▲** or **▼** to highlight **Caption Control**, then press **ENTER**. A menu opens.
- 5 Press **▲** or **▼** to select **CC Off** (turns off closed captioning), **CC On** (turns on closed captioning), or **CC On When Mute** (turns on closed captioning when the sound is muted).
- 6 Press **MENU** to return to the previous menu, or press **EXIT** to close the menu.

Note

You can also press **CCD** to turn closed captioning on or off.

Selecting the analog closed captioning mode

To select the analog closed captioning mode:

- 1 Press **MENU**. The on-screen menu opens.

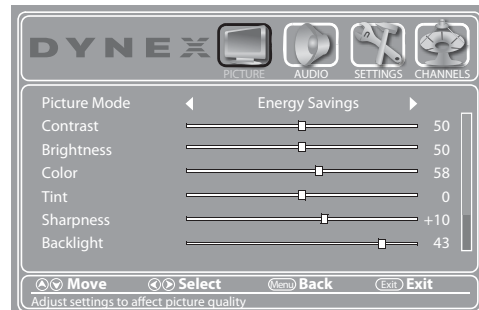

- 2 Press **◀** or **▶** to highlight **SETTINGS**, then press **▼**. The **SETTINGS** menu opens.



- 3 Press **▲** or **▼** to highlight **Closed Caption**, then press **ENTER**. The **SETTINGS-Closed Caption** menu opens.



- 4 Press **▲** or **▼** to highlight **Analog Caption**, then press **ENTER**. A menu opens.



- 5 Press **▲** or **▼** to select an analog caption setting. You can select:
 - **CC1** through **CC4**—Closed captioning appears in a small banner across the bottom of the screen. **CC1** is usually the “printed” version of the audio. **CC2** through **CC4** display content provided by the broadcaster.
 - **Text1** through **Text4**—Closed captioning that covers half or all of the screen. **Text1** through **Text4** display content provided by the broadcaster.
- 6 Press **EXIT** to close the menu.

Customizing digital closed captioning styles

To customize digital closed captioning styles:

- 1 Press **MENU**. The on-screen menu opens.

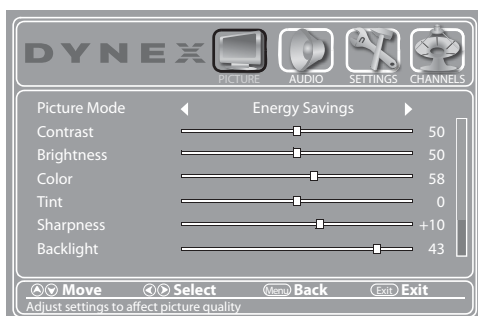

- 2 Press **◀** or **▶** to highlight **SETTINGS**, then press **▼**. The **SETTINGS** menu opens.

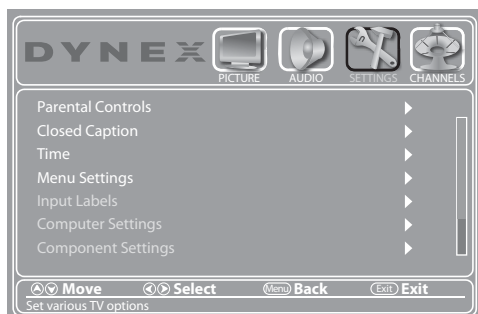

- 3 Press **▲** or **▼** to highlight **Closed Caption**, then press **ENTER**. The **SETTINGS-Closed Caption** menu opens.

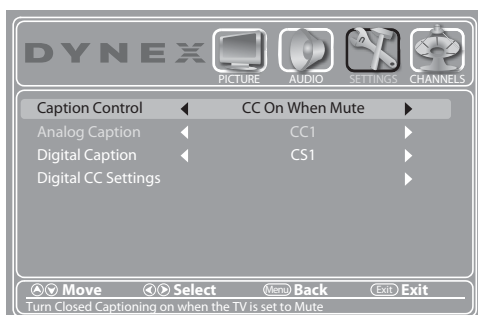

- 4 Press **▲** or **▼** to highlight **Caption Control**, then press **ENTER**. The **SETTINGS-Closed Caption** menu opens.



- 5 Press **▲** or **▼** to highlight **Digital Caption** (only available for digital stations), then press **▲** or **▼** to highlight a digital caption setting. You can select **CS1** through **CS6** or **CC1** through **CC4**.
- 6 Press **MENU** to return to the previous menu, press **▲** or **▼** to highlight **Digital CC Settings**, then press **ENTER**. The **Digital CC Settings** menu opens.



- 7 Press **▲** or **▼** to highlight **Mode**, then press **◀** or **▶** to select **Custom**.

Note

To reset the close caption styles to their defaults, set **Mode** to **Automatic**.

- 8 Press **▲** or **▼** to highlight a style, then press **◀** or **▶** to adjust the style. You can select:
 - **Font Style**—Selects the font style.
 - **Font Size**—Selects the font size.
 - **Font Edge Style**—Selects the edge style.
 - **Font Edge Color**—Selects the edge color.
 - **Font Color**—Selects the color for the words.
 - **Background Color**—Selects the color for the background.
 - **Font Opacity**—Selects the opacity level for the words.
 - **Background Opacity**—Selects the opacity level for the background.
- 9 Press **EXIT** to close the menu.

Adjusting time settings

Setting the clock

To set the clock:

- 1 Press **MENU**. The on-screen menu opens.

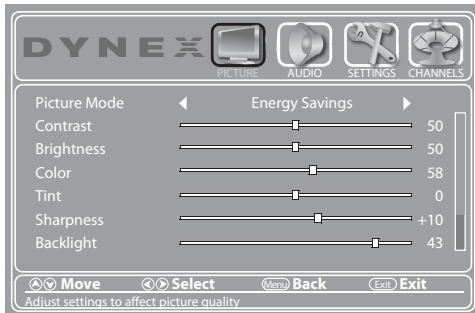

- 2 Press **◀** or **▶** to highlight **SETTINGS**, then press **▼**. The **SETTINGS** menu opens.

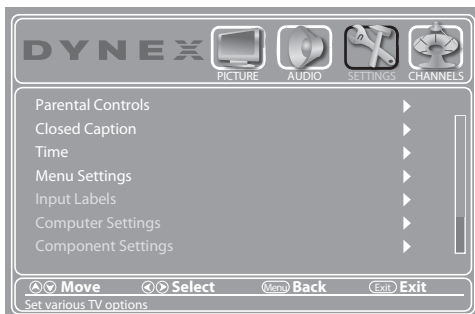

- 3 Press **▲** or **▼** to highlight **Time**, then press **ENTER**. The **SETTINGS-Time** menu opens.



- 4 Press **▲** or **▼** to highlight **Date/Time**, then press **ENTER**. The **SETTINGS-Time-Date/Time** menu opens.

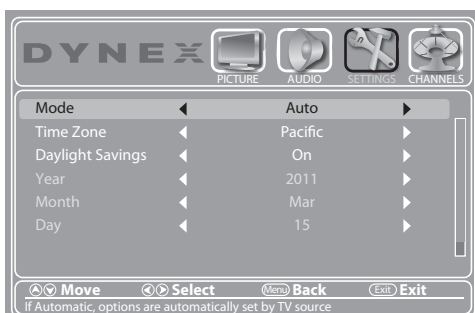

- 5 Press **▲** or **▼** to highlight **Mode**, then press **◀** or **▶** to select **Manual** (to set the date and time manually), or **Auto** (the date and time are automatically set by the TV signal source, based on the time zone you select).
- 6 Press **▲** or **▼** to highlight **Time Zone**, then press **◀** or **▶** to select your time zone. You can select **Pacific, Alaska, Hawaii, Newfoundland, Atlantic, Eastern, Central, or Mountain**.
- 7 If your viewing area observes daylight savings time, press **▲** or **▼** to highlight **Daylight Savings**, then press **◀** or **▶** to select **On**.
- 8 If you selected **Manual** for **Mode**:
 - Press **▲** or **▼** to highlight **Year, Month, or Day**, then press **◀** or **▶** to adjust the setting.
 - Press **▲** or **▼** to highlight **Time**, press **◀** or **▶** to the hour, minute, or AM/PM field, then press **▲** or **▼** to adjust the setting.
- 9 Press **EXIT** to close the menu.

Setting the sleep timer

You can specify the amount of time before your TV automatically turns off.

To set the sleep timer:

- 1 Press **MENU**. The on-screen menu opens.

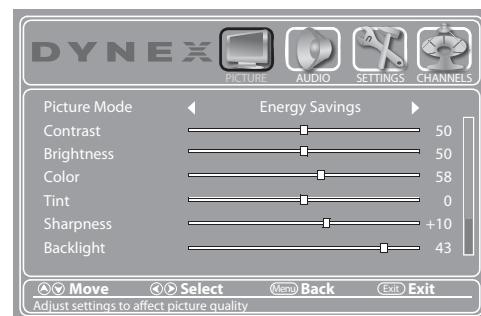

- 2 Press **◀** or **▶** to highlight **SETTINGS**, then press **▼** or **ENTER**. The **SETTINGS** menu opens.
- 3 Press **▲** or **▼** to highlight **Time**, then press **ENTER**. The **SETTINGS-Time** menu opens.



- Press **▲** or **▼** to highlight **Sleep Timer**, then press **◀** or **▶** to select the amount of time before your TV turns off automatically. To turn off the sleep timer, select **Off**.



- Press **EXIT** to close the menu.

Note
You can also press **SLEEP** to set the sleep timer.

Adjusting menu settings

Selecting the menu language

To select the menu language:

- Press **MENU**. The on-screen menu opens.

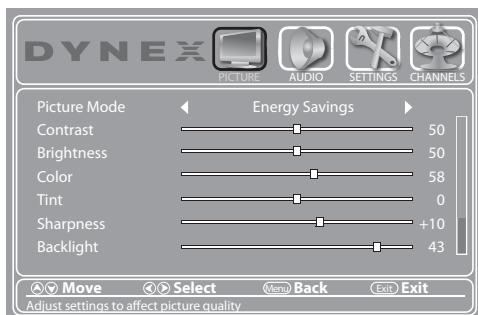

- Press **◀** or **▶** to highlight **SETTINGS**, then press **▼**. The **SETTINGS** menu opens.

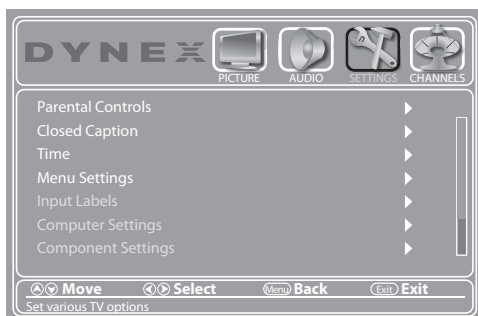

- Press **▲** or **▼** to highlight **Menu Settings**, then press **ENTER**. The **SETTINGS-Menu Settings** menu opens.
- Press **▲** or **▼** to highlight **Language**, then press **ENTER**. The **Language** menu opens.
- Press **▲** or **▼** to highlight **English, Français, or Español**, then press **ENTER** to close the menu.
- Press **EXIT** to close the menu.

Labeling an input source

To label an input source:

- Press **MENU**. The on-screen menu opens.

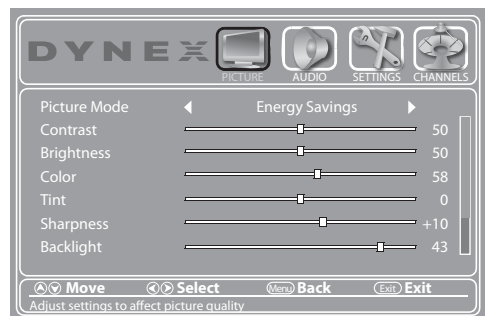

- Press **◀** or **▶** to highlight **SETTINGS**, then press **▼**. The **SETTINGS** menu opens.

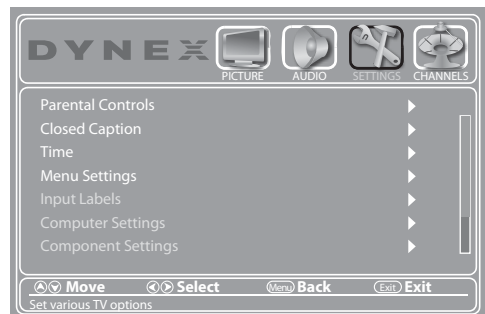

- Press **▲** or **▼** to highlight **Input Labels**, then press **ENTER**. The **SETTINGS-Input Labels** screen opens with the input source field highlighted.

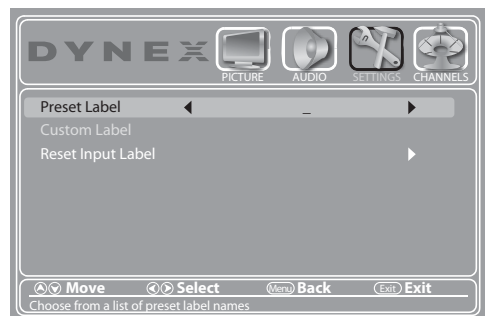

- Press **▲** or **▼** to select the input source you want to label, then press **▶** to move to the custom label field.

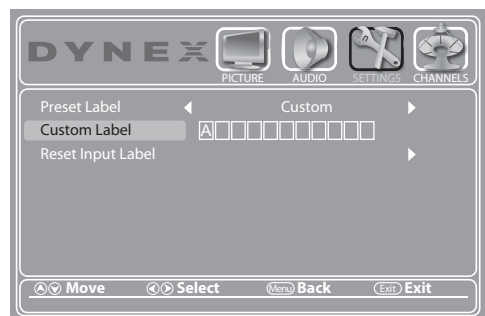

- 5 Press ▲▼◀▶ or ▶ to highlight a character, then press ENTER. Repeat this step to enter additional characters. You can enter as many as 11 characters. If you need to delete a character, then press ◀ and if you want to enter a space, select the blank.
- 6 When you have completed the label, press **MENU**. The next time you press **INPUT**, your label appears in the *Input Source* list.
- 7 Press **EXIT** to close the menu.

Restoring settings to the defaults

When you restore default settings, all the settings you have customized (except the password and parental rating) are reset.

To restore settings to the defaults:

- 1 Press **MENU**. The on-screen menu opens.

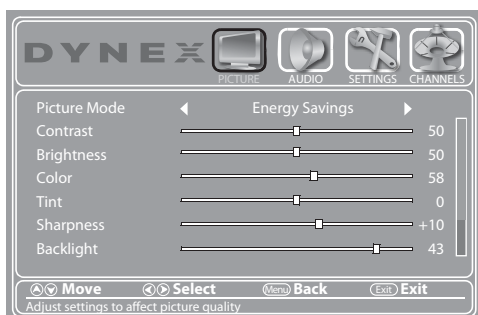

- 2 Press ◀ or ▶ to highlight **SETTINGS**, then press ▼. The *SETTINGS* menu opens.

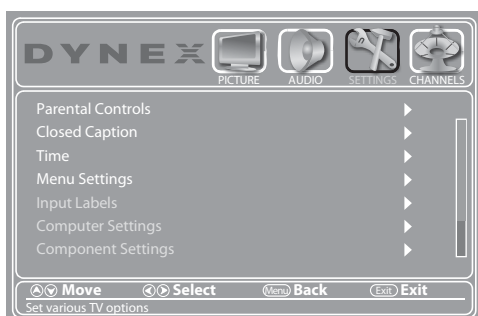

- 3 Press ▲ or ▼ to highlight **Reset to Default**, then press **ENTER**. A confirmation box opens.
- 4 Press ◀ or ▶ to select **Yes** (to reset) or **No** (to not reset), then press **ENTER**.
- 5 Press **EXIT** to close the menu.

Maintaining

- Do not use your TV in areas that are too hot or too cold, because the cabinet may warp or the screen may malfunction. Your TV works best in temperatures that are comfortable to you.
- Storage temperatures are 32° to 122°F (0° to 50°C).
- Working temperatures are 41° to 104°F (5° to 40°C).
- Do not place your TV in direct sunlight or near a heat source.

Cleaning the TV cabinet

Clean the cabinet with a soft, lint-free cloth. If the cabinet is especially dirty, moisten a soft, lint-free cloth in a weak detergent solution, squeeze the excess moisture from the cloth, then wipe the screen or cabinet with the cloth. Use a clean cloth to dry the screen or cabinet.

Cleaning the TV screen

Clean the screen with a soft, lint-free cloth.

Upgrading the firmware

To upgrade the firmware:

- Plug a USB flash drive into the **SERVICE PORT** on the side of your TV.

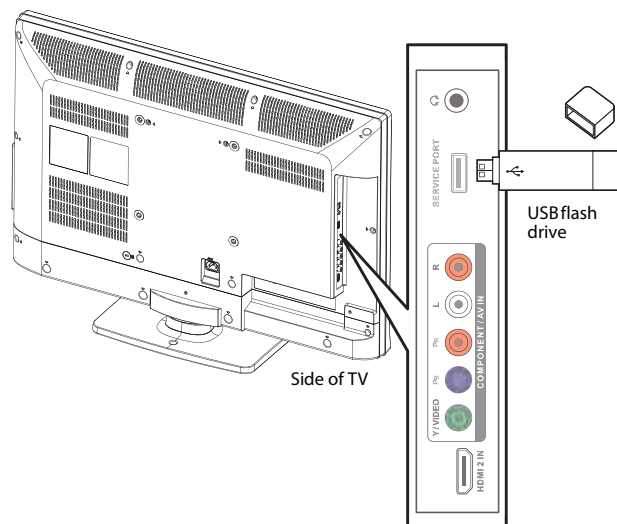

Caution

Do not remove the USB flash drive or turn off the TV while using the USB flash drive. You may lose data or damage the USB flash drive.

Notes

The USB flash drive is only for firmware upgrading.

Troubleshooting

Warning

Do not try to repair your TV yourself. Contact authorized service personnel.

Video and audio

Problem	Solution
Picture does not fill the screen. There are black bars around the picture.	<ul style="list-style-type: none"> Change the aspect ratio. An increasing amount of digital TV and movies are presented in wide screen (16:9). See "Adjusting the TV picture" on page 20.
No picture (screen is not lit) and no sound.	<ul style="list-style-type: none"> Press ⏻ on the TV or the remote control. Make sure that Audio Only option is set to Off. See "Playing TV audio only" on page 22. Make sure that the video cables are connected correctly and securely to the side of your TV. Adjust the contrast and brightness. See "Adjusting the TV picture" on page 20. Make sure that the power cord is plugged in. Make sure that the correct video input source is selected. See "Selecting the video input source" on page 18. Try another channel. The station may be experiencing problems. Make sure that the incoming signal is compatible. Make sure the antenna or cable TV is connected correctly and securely. See "Connecting a cable or satellite box" on page 8 or "Connecting an antenna or cable TV (no box)" on page 11. Check the closed caption settings. Some TEXT modes can block the screen.
Dark, poor, or no picture (screen is lit), but sound is good.	<ul style="list-style-type: none"> Try another channel. The station may be experiencing problems. Make sure that the antenna or cable TV is connected correctly and securely. See "Connecting a cable or satellite box" on page 8 or "Connecting an antenna or cable TV (no box)" on page 11. Adjust the brightness. See "Adjusting the TV picture" on page 20. Make sure that the correct picture mode is selected. See "Adjusting the TV picture" on page 20. If you are using an antenna, the digital channel signal may be low. To check the digital channel signal strength, see "Checking the digital signal strength" on page 24. If you are using an antenna and the signal strength is low, adjust the antenna or use a highly directional outdoor antenna or set-top antenna with a built-in amplifier. Make sure that the video cables are connected correctly and securely to the side of your TV. The video cable(s) you are using may be bad. Try a new set. Try another channel. The station may be experiencing problems.

Problem	Solution
No color, dark picture, or color is not correct.	<ul style="list-style-type: none"> Try another channel. The station may be experiencing problems. Adjust the color saturation. See "Adjusting the TV picture" on page 20. Make sure that the video cables are connected correctly and securely to the side of your TV. Make sure that the antenna or cable TV is connected correctly and securely. See "Connecting a cable or satellite box" on page 8 or "Connecting an antenna or cable TV (no box)" on page 11. If you are using an antenna, the digital channel signal may be low. To check the digital channel signal strength, see "Checking the digital signal strength" on page 24. If you are using an antenna and the signal strength is low, adjust the antenna or use a highly directional outdoor antenna or set-top antenna with a built-in amplifier.
Only snow (noise) appears on the screen.	<ul style="list-style-type: none"> Try another channel. The station may be experiencing problems. Make sure that the antenna or cable TV is connected correctly and securely. See "Connecting a cable or satellite box" on page 8 or "Connecting an antenna or cable TV (no box)" on page 11. If you are using an antenna, the digital channel signal may be low. To check the digital channel signal strength, see "Checking the digital signal strength" on page 24. If you are using an antenna and the signal strength is low, adjust the antenna or use a highly directional outdoor antenna or set-top antenna with a built-in amplifier.
Dotted lines or stripes appear on the screen.	<ul style="list-style-type: none"> Make sure that the antenna or cable TV is connected correctly and securely. See "Connecting a cable or satellite box" on page 8 or "Connecting an antenna or cable TV (no box)" on page 11. If you are using an antenna, the digital channel signal may be low. To check the digital channel signal strength, see "Checking the digital signal strength" on page 24. If you are using an antenna and the signal strength is low, adjust the antenna or use a highly directional outdoor antenna or set-top antenna with a built-in amplifier. Make sure that the video cables are connected correctly and securely to the side of your TV. The video cable(s) you are using may be bad. Try a new set. Other devices (for example, surround sound receiver, external speakers, fans, or hair dryers) may be interfering with your TV. Try turning off one device at a time to determine which device is causing interference. Once you have determined which device is causing interference, move it further from the TV to eliminate the interference.
Double images.	<ul style="list-style-type: none"> Use a highly directional outdoor antenna, cable TV, or satellite TV.
The picture has a few bright or dark spots.	<ul style="list-style-type: none"> A few bright or dark spots on an LCD screen is normal. It does not affect the operation of this TV.

Problem	Solution
Good picture, but no sound.	<ul style="list-style-type: none"> • Increase the volume. • Make sure that the sound is not muted. • Make sure that the correct audio mode is selected. • Make sure that the audio cables are connected correctly and securely to the back of your TV. • Make sure that the antenna or cable TV is connected correctly and securely. See "Connecting a cable or satellite box" on page 8 or "Connecting an antenna or cable TV (no box)" on page 11. • If you are using an antenna, the digital channel signal may be low. To check the digital channel signal strength, see "Checking the digital signal strength" on page 24. • The audio cable(s) you are using may be bad. Try a new set.
Poor picture	<ul style="list-style-type: none"> • Make sure that the room is not too bright. Light reflecting off the screen can make the picture difficult to see. • If an S-VHS camera or a camcorder is connected while another connected device is turned on, the picture may be poor. Turn off one or more devices.
Good sound but poor color	<ul style="list-style-type: none"> • Adjust the contrast, color, and brightness settings.
Audio noise	<ul style="list-style-type: none"> • Other devices (for example, surround sound receiver, external speakers, fans, or hair dryers) may be interfering with your TV. Try turning off one device at a time to determine which device is causing interference. Once you have determined which device is causing interference, move it further from the TV to eliminate the interference.
No output from one of the speakers	<ul style="list-style-type: none"> • Adjust the audio balance. See "Adjusting sound settings" on page 21. • Make sure that the audio cables are connected correctly and securely to the back of your TV.
After images appear	<ul style="list-style-type: none"> • Do not display a still image, such as a logo, game, or computer image, for an extended period of time. This can cause a permanent after-image to be burned into the screen. This type of damage is not covered by your warranty.

Remote control

Problem	Solution
Remote control does not work.	<ul style="list-style-type: none"> • Make sure that the power cord is correctly connected to your TV and a power outlet. • Make sure that there are no obstructions between the remote control and the remote control sensor on the front of the TV. • Point the remote control directly at the remote control sensor on your TV. For the location of the remote control sensor, see "Front" on page 5. • Make sure that the batteries are installed correctly. See "Installing remote control batteries" on page 17. • Replace dead batteries with new batteries. See "Installing remote control batteries" on page 17.
Trouble programming your existing universal remote control.	<ul style="list-style-type: none"> • See instructions and a table of common codes in "Programming a different universal remote control" on page 36. • Codes are subject to change. For up to date codes, go to www.Dynexproducts.com. • Replace dead batteries with new batteries. See "Installing remote control batteries" on page 17. • Refer to the User Guide that accompanied your universal remote control and contact the manufacturer if problems persist.

General

Problem	Solution
No power	<ul style="list-style-type: none"> • Make sure that the power cord is correctly connected to your TV and a power outlet. • Unplug the power cord, wait 60 seconds, then plug the cord back in and turn on your TV. • Other devices (for example, surround sound receiver, external speakers, fans, or hair dryers) may be interfering with your TV. Try turning off one device at a time to determine which device is causing interference. Once you have determined which device is causing interference, move it further from the TV to eliminate the interference.
"No signal" error message is displayed	<ul style="list-style-type: none"> • Press INPUT and make sure that you have selected the correct input for the device or service you are trying to use. • If you are using a cable or satellite box, use the remote that came with that box to change channels. • Make sure you have the correct input selected to view channels from the cable or satellite box.
After Auto Channel Search, there are no channels	<ul style="list-style-type: none"> • Reception can vary by channel depending on the broadcast power level of a given station. Contact your cable or satellite TV provider. • Make sure the antenna or cable/satellite TV is connected securely to your TV. • Try replacing the cable between the antenna/cable or cable/satellite box and your TV.
One or more channels do not display.	<ul style="list-style-type: none"> • Make sure that the channels are not blocked. See "Setting parental control levels." • Make sure that the channels are not hidden. The channel may have been deleted from the channel list. You can tune to the channel by pressing the number buttons or you can add the channel back to the channel list. See "Hiding channels" on page 23. • If you are using a cable or satellite box, use the remote that came with that box to change channels. • Make sure you have the correct input selected to view channels from the cable or satellite box. • If you are using an antenna, the digital channel signal may be low. To check the digital channel signal strength, see "Checking the digital signal strength" on page 24.
Password is lost.	<ul style="list-style-type: none"> • Enter 9999 to access parental controls, then set a new password. See "Setting or changing the password" on page 24.
Some settings cannot be accessed.	<ul style="list-style-type: none"> • If a setting is grayed, the setting is not available in the current video input mode.
TV cabinet creaks.	<ul style="list-style-type: none"> • When the TV is in use, the temperature rises naturally and may cause the cabinet to expand or contract which can cause a creaking noise. This is not a malfunction.
Control buttons do not work	<ul style="list-style-type: none"> • Make sure that the Button Lock option is set to Off. See "Locking control buttons" on page 25. • Unplug the power cord, wait a few seconds, then plug the cord back in and turn on your TV.
TV keeps turning off	<ul style="list-style-type: none"> • Make sure that the sleep timer is not turned on. See "Setting the sleep timer" on page 30.

Note
If the problem is not solved by using these troubleshooting instructions, turn off your TV, then turn it on again.

Specifications are subject to change without notice.

Warranty

DX-32L221A12	DX-40L260A12
Parts: 1 year	Parts: 1 year
Labor: 1 year	Labor: 1 year

Dimensions and weight

DX-32L221A12	DX-40L260A12
Without stand: 30.63 × 20.03 × 3.85 in. (77.81 × 50.88 × 9.79 cm)	Without stand: 38.21 × 24.66 × 3.50 in. (97.06 × 62.65 × 8.91 cm)
With stand: 30.63 × 21.77 × 9.06 in. (77.81 × 55.3 × 23.0 cm)	With stand: 38.21 × 26.77 × 10.24 in. (97.06 × 68.02 × 26.01 cm)
Without stand: 18.61 lbs. (8.44 kg)	Without stand: 32.19 lbs. (14.6 kg)
With stand: 19.62 lbs. (8.9 kg)	With stand: 33.73 lbs. (15.3 kg)

Screen

	DX-32L221A12	DX-40L260A12
Screen size measured diagonally	31.5"	40"
Display type	LCD	LCD
Panel 60 Hz vs. 120 Hz	60Hz	60Hz
Display resolution	720p	1080p
Panel resolution	1366 (H) × 768 (V)	1920 (H) × 1080 (V)
Aspect ratio	16:9	16:9
Contrast ratio (typical)–panel	1200:1	4000:1
Dynamic contrast ratio (typical)–list value	4000:1	12000:1
Brightness (center typical) cd/m2–panel	350	430
Comb filter	3d y/c digital	3d y/c digital
Response time	9 ms	8 ms
Horizontal viewing angle (typical)	178	178
Vertical viewing angle (typical)	178	178

Display resolutions/VGA scan rates

	DX-32L221A12	DX-40L260A12
HDMI	Suggested Resolutions: 1080p, 1080i, 720p, 480p, 480i	Suggested Resolutions: 1080p, 1080i, 720p, 480p, 480i
Component video	Suggested Resolutions: 1080i, 720p, 480p, 480i	Suggested Resolutions: 1080i, 720p, 480p, 480i

	Suggested scan rates:	Suggested scan rates:
PC/VGA	720 × 400/70Hz, 640 × 480/60Hz, 640 × 480/72Hz, 640 × 480/75Hz, 800 × 600/56Hz, 800 × 600/60Hz, 800 × 600/75Hz, 1024 × 768/60Hz, 1024 × 768/70Hz, 1024 × 768/75Hz, 1280 × 768/60Hz, 1280 × 768/60Hz, 1360 × 768/60Hz	720 × 400/70Hz, 640 × 480/60Hz, 640 × 480/72Hz, 640 × 480/75Hz, 800 × 600/56Hz, 800 × 600/60Hz, 800 × 600/75Hz, 1024 × 768/60Hz, 1024 × 768/70Hz, 1024 × 768/75Hz, 1280 × 768/60Hz, 1280 × 1024/60Hz, 1280 × 1024/75Hz, 1920 × 1080/60Hz

Tuner

	DX-32L221A12	DX-40L260A12
Analog	NTSC	NTSC
Digital	ATSC, 8-VSB, Clear-QAM	ATSC, 8-VSB, Clear-QAM

Inputs

	DX-32L221A12	DX-40L260A12
HDMI	1 (side), 1 (back) E-EDID compliant HDCP compliant	1 (side), 1 (back) E-EDID compliant HDCP compliant
Component video	1 (side)	1 (side)
Composite video	1 (side) Share with Component-Y	1 (side) Share with Component-Y
Shared audio (component and composite)	Yes	Yes
S-Video	No	No
PC/VGA	1 (back)	1 (back)
3.5mm PC audio input	1 (back)	1 (back)
DVI	1- HDMI port 1 (back)	1- HDMI port 1 (back)
USB (SERVICE PORT)	1 (side) Firmware upgrade only	1 (side) Firmware upgrade only

Outputs

	DX-32L221A12	DX-40L260A12
Video	No	No
Analog audio	1 (back)	1 (back)
Digital audio	1 (back)	1 (back)
WiFi	No	No
Ethernet	No	No
Headphone	1 (side)	1 (side)

Audio

	DX-32L221A12	DX-40L260A12
Simulated Surround Sound	No	No
Audyssey Dynamic Volume	No	No
Sound Leveler	Yes	Yes
Watts/Channel	8W x 2	10W x 2
Number of Speakers	2	2

Power

	DX-32L221A12	DX-40L260A12
Power consumption	On: 135 W Standby: <1 W	On: 195 W Standby: < 1 W
Power input	120V/60Hz	120V/60Hz

Miscellaneous

	DX-32L221A12	DX-40L260A12
OSD languages	English, French, Spanish	English, French, Spanish
INlink	No	No
Game Mode	No	No
ENERGY STAR qualified	No	No
Internet connectable	No	No
TV base screws	Q4 type (25 mm length) (4 pcs)	Q4 type (25 mm length) (4 pcs)
V-Chip (version 2.0)	Yes	Yes
Sleep timer	Yes	Yes
Channel labeling	Yes	Yes
VESA mount (mm) (horizontal × vertical)	200 × 200	200 × 200

Note

The length of the wall-mount screws vary depending on the wall-mount bracket you purchased. See the instructions that came with the wall-mount bracket for screw lengths.

Programming universal remote controls

Programming a different universal remote control

You can operate your Dynex TV with a new or existing universal remote control.

To program a different universal remote control:

- 1 See the table below for common codes. If you have problems programming your remote or need a different remote control code, visit www.dynexproducts.com/remotecodes for the latest remote control code information.
- 2 Follow your universal remote control's instructions to enter the TV code you found in Step 1.

Tips

- If your universal remote control has a code search feature, run a code search to identify a code that matches your TV. See your universal remote control's instructions for details.
- If your universal remote control has a "Learn" feature, you can manually program it using the Dynex TV remote to "teach" the commands one at a time. See your universal remote control's instructions for details.

For additional help and information...

1. Visit <http://www.dynexproducts.com/remotecodes>
2. Call technical support for the universal remote control or cable/satellite company of the remote/set-top box you are trying to program.
3. Call the Dynex Customer Care Center 1-800-305-2204.

Common universal remote control codes

Note

- This note only goes with TV/Blu-ray or TV/DVD combos.
- The following codes may not provide full functionality. You may need to use the remote control that came with your TV, especially to control the Blu-ray or DVD functions.

The following is a list of the most common remote control codes. Codes for other remote controls are available online at: www.dynexproducts.com/remotecodes, or check with your cable or satellite TV provide for the remote control code.

Dynex TV codes for universal remote controls (for all Dynex TVs manufactured after Jan. 1, 2007)

Universal remote control makes and models	
One for All	0054
Phillips	0198, 0490
RCA	135
Sony	068, 069, 078, 096, 100, 164, 168, 229, 026

Set-top box makes and models	
Cablevision	068, 069, 078, 096, 100, 164, 168, 229, 026
Charter	2002, 1204, 1423, 1517, 0171, 1963, 0463, 0842, 1326, 167, 415, 424, 450, 456, 461, 507, 523, 567, 577, 586
Comcast	10171, 11204, 11326, 11517, 11641, 11780, 11892, 11963, 12002
Cox	1326, 1463
DirectTV	10171, 11204, 11326, 11517, 11564, 11641, 11963, 12002
Dish Network	720
Time Warner	400, 450, 461, 456, 10463, 1463, 0463
TiVo	0091
Verizon	0198, 0490

Tips

- The brand name is often visible on the front of the universal remote control, and the model number is often visible on the back.
- If your universal remote control isn't listed on the chart, refer to your universal remote control's instructions and try codes for the brands Orion, Emerson, Memorex, Sansui, Sylvania, or Zenith. You may need to try several codes before finding a match.

Legal notices

FCC Part 15

This device complies with Part 15 of the FCC Rules. Operation of this product is subject to the following two conditions: (1) this device may not cause harmful interference, and (2) this device must accept any interference received, including interference that may cause undesired operation.

This equipment has been tested and found to comply within the limits for a class B digital device, pursuant to Part 15 of the FCC Rules. These limits are designed to provide reasonable protection against harmful interference in a residential installation. This equipment generates, uses, and can radiate radio frequency energy and, if not installed and used in accordance with the instructions, may cause harmful interference to radio communications. However, there is no guarantee that interference will not occur in a particular installation. If this equipment does cause harmful interference to radio or television reception, which can be determined by turning the equipment off and on, the user is encouraged to try to correct the interference by one or more of the following measures:

- Reorient or relocate the receiving antenna.
- Increase the separation between the equipment and receiver.
- Connect the equipment into an outlet on a circuit different from that to which the receiver is connected.
- Consult the dealer or an experienced radio/TV technician for help.

FCC warning

Changes or modifications not expressly approved by the party responsible for compliance with the FCC Rules could void the user's authority to operate this equipment.

Cables

Connections to this device must be made with shielded cables with metallic RF/EMI connector hoods to maintain compliance with FCC Rules and Regulations.

Canada ICES-003 statement

This Class B digital apparatus complies with Canadian ICES-003.
Standard Television Receiving Apparatus — Appareil de réception télévision ordinaire,
Canada BETS-7 / NTMR-7

Dolby License Notice and Trade ark Acknowledgement



Manufactured under license from Dolby Laboratories. Dolby and the double-D symbol are trademarks of Dolby Laboratories.

HDMI



HDMI, the HDMI logo, and High-Definition Multimedia Interface are trademarks or registered trademarks of HDMI Licensing LLC.

OPEN SOURCE SOFTWARE

For OPEN SOURCE SOFTWARE information, refer to the System information section in the on-screen display (OSD) on the TV.

If you require additional information or you wish to receive the complete corresponding GPL or LGPL licensed source code, please call the Dynex support line at 1-800-305-2204. This source code is available for a period of three (3) years from the date of the distribution of this product by Dynex.

One-year limited warranty - Dynex Televisions

US and Canada Market

Definitions:

Dynex Products ("Dynex") warrants to you, the original purchaser of this new Dynex-branded television ("Product"), that the Product shall be free of defects in the original manufacturer of the material or workmanship for a period of one (1) year from the date of your purchase of the Product ("Warranty Period"). For this warranty to apply, your Product must be purchased in the United States or Canada from a Best Buy or Future Shop authorized dealer of Dynex brand products only that are packaged with this warranty statement.

How long does the coverage last?

The Warranty Period lasts for 1 year (365 days) from the date you purchased the Product. Your purchase date is printed on the receipt you received with the Product.

What does this warranty cover?

During the Warranty Period, if the original manufacture of the material or workmanship of the Product is determined to be defective by an authorized Dynex repair center or store personnel, Dynex will (at its sole option): (1) repair the Product with new or rebuilt parts; or (2) replace the Product at no charge with new or rebuilt comparable products or parts. Products and parts replaced under this warranty become the property of Dynex and are not returned to you. If service of Products or parts are required after the Warranty Period expires, you must pay all labor and parts charges. This warranty lasts as long as you own your Dynex Product during the Warranty Period. Warranty coverage terminates if you sell or otherwise transfer the Product.

How to obtain warranty service?

If you purchased the Product at a Best Buy or Future Shop retail store location and your television Product has a screen size of less than 37 inches, please take your original receipt and the Product to any Best Buy or Future Shop store. Make sure that you place the Product in its original packaging or packaging that provides the same amount of protection as the original packaging. If you purchased the Product from a Best Buy or Future Shop online web site, mail your original receipt and the Product to the address listed on the web site. Make sure that you put the Product in its original packaging or packaging that provides the same amount of protection as the original packaging. To obtain in-home warranty service for a television with a screen 37 inches or larger, in the United States call 1-888-BESTBUY, Canada call 1-866-BESTBUY for Future Shop call 1-800-663-2275. Call agents will diagnose and correct the issue over the phone or will have a Dynex-approved repair technician dispatched to your home.

Where is the warranty valid?

This warranty is valid only to the original purchaser of the product in the United States and Canada at Best Buy or Future Shop branded retail stores or websites.

What does the warranty not cover?

This warranty does not cover:

- Customer instruction/education
- Installation
- Set up adjustments
- Cosmetic damage
- Damage due to acts of God, such as power surges
- Accident(s)
- Misuse
- Abuse
- Negligence
- Commercial purposes/use, including but not limited to use in a place of business or in communal areas of a multiple dwelling condominium or apartment complex, or otherwise used in a place of other than a private home.
- Modification of any part of the Product, including the antenna
- Plasma display panel damaged by static (non-moving) images applied for lengthy periods (burn-in).
- Damage due to incorrect operation or maintenance
- Connection to an incorrect voltage or power supply
- Attempted repair by any person not authorized by Dynex to service the Product
- Products sold "as is" or "with all faults"
- Consumables, including but not limited to batteries (i.e. AA, AAA, C etc.)
- Products where the factory applied serial number has been altered or removed
- Loss or Theft of this product or any part of the product

- Up to three (3) pixel failures (dots that are dark or incorrectly illuminated) grouped in an area smaller than one tenth (1/10) of the display size or up to five (5) pixel failures throughout the display. (Pixel based displays may contain a limited number of pixels that may not function normally.)
- Failures or Damage caused by any contact including but not limited to liquids, gels or pastes.

REPAIR REPLACEMENT AS PROVIDED UNDER THIS WARRANTY IS YOUR EXCLUSIVE REMEDY FOR BREACH OF WARRANTY. DYNEX SHALL NOT BE LIABLE FOR ANY INCIDENTAL OR CONSEQUENTIAL DAMAGES FOR THE BREACH OF ANY EXPRESS OR IMPLIED WARRANTY ON THIS PRODUCT, INCLUDING, BUT NOT LIMITED TO, LOST DATA, LOSS OF USE OF YOUR PRODUCT, LOST BUSINESS OR LOST PROFITS. DYNEX PRODUCTS MAKES NO OTHER EXPRESS WARRANTIES WITH RESPECT TO THE PRODUCT, ALL EXPRESS AND IMPLIED WARRANTIES FOR THE PRODUCT, INCLUDING, BUT NOT LIMITED TO, ANY IMPLIED WARRANTIES OF AND CONDITIONS OF MERCHANTABILITY AND FITNESS FOR A PARTICULAR PURPOSE, ARE LIMITED IN DURATION TO THE WARRANTY PERIOD SET FORTH ABOVE AND NO WARRANTIES, WHETHER EXPRESS OR IMPLIED, WILL APPLY AFTER THE WARRANTY PERIOD. SOME STATES, PROVINCES AND JURISDICTIONS DO NOT ALLOW LIMITATIONS ON HOW LONG AN IMPLIED WARRANTY LASTS, SO THE ABOVE LIMITATION MAY NOT APPLY TO YOU. THIS WARRANTY GIVES YOU SPECIFIC LEGAL RIGHTS, AND YOU MAY ALSO HAVE OTHER RIGHTS, WHICH VARY FROM STATE TO STATE OR PROVINCE TO PROVINCE.

Contact Dynex:

For customer service please call 1-800-305-2204

www.Dynexproducts.com

Distributed by Best Buy Purchasing, LLC

7601 Penn Avenue South, Richfield, Minnesota, U.S.A. 55423-3645

© 2011 BBY Solutions, Inc.

All rights reserved. DYNEX is a trademark of BBY Solutions, Inc. Registered in some countries. All other products and brand names are trademarks of their respective owners.

DYNEX™

www.dynexproducts.com
US and Canada Market - (800) 305-2204

Distributed by Best Buy Purchasing, LLC
7601 Penn Ave. South, Richfield, MN 55423 U.S.A.
© 2011 BBY Solutions, Inc. All rights reserved.

DYNEX is a trademark of BBY Solutions, Inc. Registered in some countries. All other products and brand names are trademarks of their respective owners.

ENGLISH
11-0101